

PHILOSOPHY 3201B

Section 001 UWO

A Second Course in Logic

Prof. John Bell

January 2016

Book No. M9718

Contents

I. Set Theory	1
II. Review of Predicate Logic	13
III. Postulate Systems for Arithmetic	24
IV. Second-Order Logic	30
V. Contextual (Modal) Logic	36
VI. Intuitionistic Logic	54
VII. Intuitionistic Contextual Logic	72
Solutions to Selected Exercises	86

Chapter I
Set Theory

I. Set Theory

SETS

Logic has a close relationship with *set theory*. We begin by describing some of its basic concepts which will prove useful in our further development of logic.

We are all familiar with the idea of a *set*, also called a *class* or *collection*. As examples, we may consider the set of all coins in one's pocket, the set of all human beings, the set of all planets in the solar system, etc. These are all *concrete* sets in the sense that the objects constituting them—their *elements* or *members*—are material things. In mathematics and logic we wish also to consider *abstract* sets whose members are not necessarily material things, but abstract entities such as numbers, lines, ideas, names, etc. We shall use the term *set* to cover concrete and abstract sets, as well as sets which contain a mixture of material and abstract elements.

If S is a set, and a is an element of S , we say that a *belongs to* S , and write

$$a \in S.$$

If b does not belong to S , we write $b \notin S$.

In a given context, there will be a set to which all the objects we wish to consider belong: this set is called the *universal set* or *universe* for that context and will be denoted by U . It is important to remember that the universal set will not always be the same but will vary with the context: it can, in fact, be any set whatsoever. For example, if we are discussing the properties of the natural number system, U will be the set of all natural numbers. If we are discussing people, we shall want U to be the set of all human beings.

Once a universal set has been specified, we can consider *predicates* and *relations* defined on it. Suppose, for instance, that the universal set U is the set of all people. Then examples of predicates defined on U are the expressions

$$x \text{ is female} \quad x \text{ is male} \quad x \text{ is Canadian}$$

and examples of relations on U are the expressions

x is taller than y x is married to y .

Here x and y are being used as *variables* which are understood to *range* over U . This means that, when the variables in each expression are replaced by names of elements of U (in the case at hand, names of human beings), a statement having a definite *truth value* is obtained. (If the resulting statement is true, the elements are said to *satisfy* the predicate or relation in question.) For example, if in the expression x is *Chinese* we replace " x " by "*Arnold Schwarzenegger*" we obtain the false statement

Arnold Schwarzenegger is Chinese,

while if in the expression x is taller than y we make the same substitution for x and replace " y " by "*Danny de Vito*" we obtain the true statement

Arnold Schwarzenegger is taller than Danny de Vito.

The most direct way of specifying a set is to list its elements explicitly. Thus, for example,

$\{2, 3, \textit{Romeo}, \textit{Juliet}\}$

denotes the set whose elements are the numbers 2, 3 and the persons Romeo and Juliet. And

$\{\textit{Juliet}\}$

denotes the set whose sole member is Juliet. This notation is, however, of no use when the number of members of the set we are trying to specify is infinite, or finite but excessively large. To specify such sets we must instead state the characteristic property that an object must have to be a member of the set. *Predicates* are used for this purpose. For example,

$\{x: x \textit{ is Canadian}\}$

denotes the set of all people who are Canadian, with the understanding that the variable x ranges over the universal set of all people. Similarly,

$\{x: \exists y(x = y^2)\}$

denotes the set of all natural numbers which are perfect squares, provided that it is understood that the variables x and y range over the universal set of all natural numbers. In general, if $P(x)$ is a predicate defined on a universal set U , we write

$$\{x: P(x)\}$$

to denote the set of all elements of U satisfying the predicate $P(x)$. This set is called the set *determined* by P .

It is also convenient to have a notation for the *empty* set, that is, the set which has *no* members. We use the symbol \emptyset to denote this set. Thus, for example, if x ranges over the the natural numbers, $\{x: x^2 = 2\}$ is identical with \emptyset . This is the case because there is no natural number whose square is 2.

Two sets A , B are said to be *equal*, and (as usual) we write $A = B$ if they have the same members, that is, if

$$\forall x(x \in A \Leftrightarrow x \in B).$$

If the sets A and B are determined by predicates P and Q defined over a common universal set U , that is, if A is $\{x: P(x)\}$ and B is $\{x: Q(x)\}$, then

$$A = B \Leftrightarrow \forall x[P(x) \Leftrightarrow Q(x)].$$

That is, two sets are equal exactly when their determining predicates are equivalent. This observation is constantly employed in establishing the equality of sets.

If A and B are sets, we say that A is a *subset* of B , or that A is *included* or *contained* in B and write

$$A \subseteq B$$

if every member of A is a member of B , that is, if

$$\forall x(x \in A \Rightarrow x \in B).$$

For example,

$$A = \{1, 2, 3\} \subseteq \{0, 1, 2, 3\} = B.$$

Notice that this is *not* the same as $A \in B$, since the elements of B are 0, 1, 2, 3 and A is not one of these.

Exercise. Prove that the empty set is a subset of every set.

Clearly

$$A = B \Leftrightarrow (A \subseteq B \ \& \ B \subseteq A).$$

If A and B are determined by predicates P and Q defined on a universal set U , then

$$A \subseteq B \Leftrightarrow \forall x[P(x) \Rightarrow Q(x)].$$

Each predicate P defined on a universal set U determines a subset of U , namely $\{x: P(x)\}$. And conversely, each subset A of U determines a predicate defined on U , namely the predicate $x \in A$. In view of this predicates defined on a universal set and subsets of that set "amount to the same thing".

As is the case for propositional logic, it is often convenient to depict relationships between sets by means of *Venn* (or *Euler*) diagrams. For example, the diagram below depicts the relation $A \subseteq B$. The universal set U is represented by the square and the sets A and B by the regions within the square.

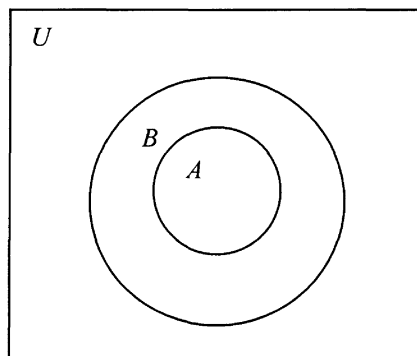

If A is a set, considered as a subset of a universal set U , its *complement* $\mathbf{C}A$ is defined by

$$\mathbf{C}A = \{x: x \notin A\}.$$

In the diagram below, A is represented by the circle. It can be seen from this diagram that $\mathbf{C}A$ depends on the universal set U .

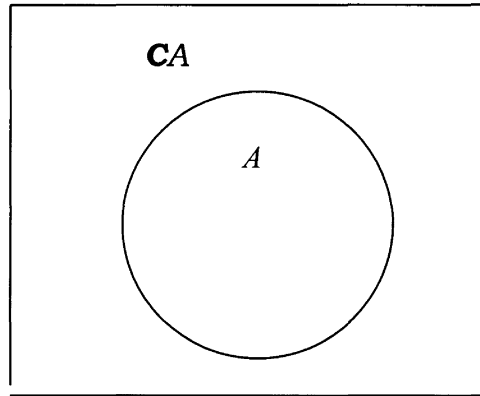

For example, if A is the set of positive natural numbers, and U the set of all natural numbers, then $\mathbf{C}A$ is $\{0\}$, while if U is the set of all integers, then A is the set $\{\dots, -2, -1, 0\}$.

If A and B are sets, their *union* $A \cup B$ and *intersection* $A \cap B$ are defined by

$$A \cup B = \{x: x \in A \vee x \in B\}, \quad A \cap B = \{x: x \in A \wedge x \in B\},$$

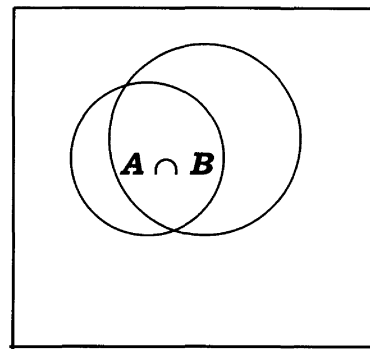
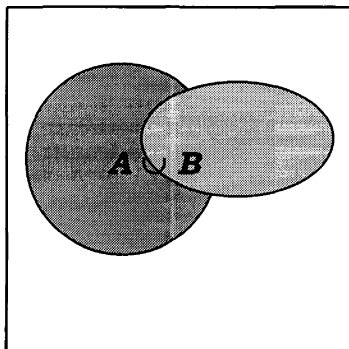

For example,

$$\{1,2,3\} \cap \{2,3,4\} = \{2,3\}, \quad \{1,2,3\} \cup \{2,3,4\} = \{1,2,3,4\}, \quad \{1,2,3\} \cap \{0,4\} = \emptyset$$

$$\{x: x \leq 0\} \cap \{x: x \geq 0\} = \{0\}$$

Exercises. 1. Draw Venn diagrams to illustrate the relations **(i)** not $A \subseteq B$, **(ii)** A and B are *disjoint*, that is, $A \cap B = \emptyset$.

2. Prove that, for any subsets A, B, C of a universal set U : **(i)** $\mathbf{C}CA = A$ **(ii)** $A \subseteq A$; **(iii)** $A \cup \mathbf{C}A = U$; **(iv)** $A \cap \mathbf{C}A = \emptyset$; **(v)** $A \cap (B \cup C) = (A \cap B) \cup (A \cap C)$; **(vi)** $A \cup (B \cap C) = (A \cup B) \cap (A \cup C)$; **(vii)** $A \cap (B \cap C) = (A \cap B) \cap C$; **(viii)** $A \cup (B \cup C) = (A \cup B) \cup C$; **(ix)** $\mathbf{C}(A \cap B) = \mathbf{C}A \cup \mathbf{C}B$; **(x)** $\mathbf{C}(A \cup B) = \mathbf{C}A \cap \mathbf{C}B$. Draw Venn diagrams to depict these.

3. For subsets A, B of a universal set U , prove that the following are equivalent: **(a)** $A \subseteq B$, **(b)** $\mathbf{C}B \subseteq \mathbf{C}A$, **(c)** $A \cup B = B$, **(d)** $A \cap B = A$, **(e)** $A \cap \mathbf{C}B = \emptyset$ **(f)** $\mathbf{C}A \cup B = U$.

4. Let $A - B$ —the *relative complement of B in A* —denote the set $\{x: x \in A \wedge x \notin B\}$. Draw a Venn diagram to depict $A - B$. **(i)** Prove that $A - B = A - (A \cap B)$, $A = (A \cap B) \cup (A - B)$. **(ii)** Are the following always true? $(A - B) \cup B = A$, $(A - B) - B = A$.

RELATIONS

Given any two individuals a, b , we assume that we can form another individual (a, b) called the *ordered pair* with *first component* a and *second component* b . If a and b are distinct, the ordered pair (a, b) will be held to be different from the ordered pair (b, a) : it follows that (a, b) cannot be the same as the set $\{a, b\}$, since always $\{a, b\} = \{b, a\}$. Generally speaking, ordered pairs (a, b) and (c, d) are said to be *equal* precisely when their first and second components are pairwise identical, that is, if $a = c$ and $b = d$. Thus

$$(*) \quad (a, b) = (c, d) \Leftrightarrow a = c \wedge b = d.$$

The concept of ordered pair can be introduced in a variety of ways, for instance by defining

$$(a, b) = \{\{a\}, \{a, b\}\}.$$

We shall not, however, be concerned with the exact definition of (a, b) : we will only need to know that it satisfies condition (*) above.

We shall also assume that we can form ordered triples (a, b, c) , quadruples (a, b, c, d) —in general, for any $n \geq 2$, ordered n -tuples (a_1, \dots, a_n) . Again, all we need to know about these is that

$$(a_1, \dots, a_n) = (b_1, \dots, b_n) \Leftrightarrow a_1 = b_1 \wedge \dots \wedge a_n = b_n.$$

Given two sets A, B , the set of all ordered pairs (a, b) with $a \in A$ and $b \in B$ is called the *Cartesian product* of A and B : it is denoted by $A \times B$. Cartesian products arise frequently in mathematics (and implicitly in logic): for instance, since each point in the euclidean plane can be identified by an ordered pair of coordinates, the plane itself can be described as the Cartesian product of two lines. (This fact was essentially known to Descartes—hence the term "Cartesian".)

Similarly, given n sets A_1, \dots, A_n , the set of all ordered n -tuples (a_1, \dots, a_n) with $a_1 \in A_1, \dots, a_n \in A_n$ is called the *Cartesian product* of A_1, \dots, A_n and denoted by $A_1 \times \dots \times A_n$. If all the A 's are identical with a fixed set A , then $A_1 \times \dots \times A_n$ is written A^n and called the n^{th} (Cartesian) *power* of A .

Exercise. (i) Prove that $A \times (B \cup C) = (A \times B) \cup (A \times C)$, $A \times (B \cap C) = (A \times B) \cap (A \times C)$, $A \times (B - C) = (A \times B) - (A \times C)$.
(ii) If $C \neq \emptyset$, prove that $A \subseteq B \Leftrightarrow A \times C \subseteq B \times C$.

We often have occasion to consider *binary relations*. A binary relation may be regarded as a *property of ordered pairs*, that is, as a *predicate defined on a Cartesian product of two sets*. Since, as we have observed, a predicate defined on a set amounts to the same thing as a subset of that set, it follows that *a binary relation is essentially just a subset of a Cartesian product of two sets*. This is best illustrated by an example.

Consider the binary relation of *marriage* between women and men. Writing W for the set of women, and M for the set of men, the marriage relation may be identified with the set R of ordered pairs (a, b) in which a is a woman, b is a man, and a is married to b . Thus R is a subset of $W \times M$: we naturally say that R is a *relation between W and M* . In general, a subset of the Cartesian product $A \times B$ of two sets A and B is called a (binary) *relation between A and B* . If H denotes the set of all human beings, then the marriage relation R is clearly also a subset of $H \times H$: it is accordingly natural to say that R is a *relation on H* .

Generally, a subset of a Cartesian product $A \times A$ is called a (binary) *relation on* A .

Similarly, a subset of $A_1 \times \dots \times A_n$ is called a *relation among* A_1, \dots, A_n and a subset of a Cartesian power A^n an *n -ary relation on* A .

If R is an n -ary relation, it is customary to write $Ra_1\dots a_n$ for $(a_1, \dots, a_n) \in R$. More particularly, if R is a binary relation, it is common practice to write aRb for Rab : the former is read " a bears the relation R to b ".

Exercises. 1. Let A, B, C be sets, let R be a relation between A and B , and let S be a relation between B and C . We define the *composite relation* $S \circ R$ between A and C to be the set of all pairs (a, c) with $a \in A, c \in C$ such that, for some $b \in B$, we have aRb and bSc . Let R, S be the parenthood and sisterhood relations on the set of human beings. What are $S \circ R, R \circ S, R \circ R, S \circ S$?

2. If R is a relation between sets A and B , the *inverse relation* R^{-1} between B and A is defined to be the set of all pairs (b, a) such that aRb .

(i) What is R^{-1} when R is **(a)** the marriage relation, **(b)** the parenthood relation, **(c)** the brotherhood relation, on the set of human beings?

(ii) Let R be a relation between A and B , and S a relation between B and C . Prove that $(S \circ R)^{-1} = R^{-1} \circ S^{-1}$, and that $(R^{-1})^{-1} = R$.

EQUIVALENCE RELATIONS

The idea of *equivalence* is of universal importance: in fact all abstractions met with in everyday life involve this idea. For instance, a hitchhiker seeking a ride in a passing vehicle will ignore all the properties of such a vehicle except its mobility: as far as he or she is concerned, all moving vehicles are equivalent, regardless of type.

This idea of equivalence is given precise expression in set theory through the concept of *equivalence relation*. An *equivalence relation* on a set A is a relation R on A satisfying the following conditions for all a, b, c in A :

- (i) *reflexivity*: aRa ,
- (ii) *symmetry*: $aRb \Leftrightarrow bRa$
- (iii) *transitivity*: $(aRb \wedge bRc) \Rightarrow aRc$.

As examples of equivalence relations we have:

The *identity relation* on any set A consisting of all ordered pairs of the form (a, a) with a in A .

The relation R on the set of all human beings defined by $aRb \Leftrightarrow a$ and b have the same parents.

The relation R on the set of natural numbers defined by $mRn \Leftrightarrow m$ and n have the same remainder when divided by 2.

The relation of *logical equivalence* on the set of all statements.

If R is an equivalence relation on a set A , and $a \in A$, the *equivalence class* of R containing a , written a_R , is the set comprising all members of A which bear the relation R to a , that is,

$$a_R = \{x: xRa\}.$$

For example, the equivalence classes of the first three relations above are, respectively. all sets of the form $\{a\}$ for $a \in A$; all families of siblings; the set of even numbers and the set of odd numbers.

Exercise. Prove that any two equivalence classes are either disjoint, or identical.

ORDERINGS

The idea of an *ordering relation*, or *ordering*, is another important concept in everyday life. Whenever we make a comparison, for example, when we say that something is bigger, or heavier, or more interesting than something else, we are implicitly employing the idea of ranking or ordering with respect to the property in question.

In set theory this idea is captured by making the following definition. An *ordering* on a set A is a relation—often written “ \leq ”—on A which is *reflexive*: $a \leq a$, *transitive*: $(a \leq b \text{ and } b \leq c) \Rightarrow a \leq c$ and *antisymmetric*: $a \leq b \text{ and } b \leq a \Rightarrow a = b$. If in addition \leq satisfies the condition of *totality*: for all a, b in A , $a \leq b$ or $b \leq a$, then \leq is called a *total ordering* on A . An ordering which is not total will be referred to as a *partial ordering*. If \leq is an ordering (partial or total) on A , we will say that A is *partially* or *totally ordered* by \leq .

Examples. (i) The set of natural numbers is *totally ordered* by the relation \leq of *increasing magnitude*. It is *partially ordered* by the relation $|$ of *divisibility*: $m | n \Leftrightarrow m$ is a divisor of n .

(ii) The *power set* $\mathbf{P}A$ of a set A is the set whose elements are all subsets of A . (For example, if $A = \{1, 2\}$, then $\mathbf{P}A = \{\emptyset, \{1\}, \{2\}, \{1, 2\}\}$.) If A has more than one element, the *inclusion relation* \subseteq is a partial ordering on A . (**Exercise:** prove this.)

Exercises. 1. If \leq is a (partial, total) ordering on a set A , prove that its inverse \leq^{-1} is also a (partial, total) ordering on A .

2. A relation on a set A which is both reflexive and transitive is called a *preordering* on A . For example, the relation *at least as tall as* is a preordering on the set of human beings.

(i) Prove that the relation p *logically implies* q is a preordering on the set of all statements.

(ii) If R is a preordering on A , prove that the relation S defined by $aSb \Leftrightarrow (aRb \wedge bRa)$ is an equivalence relation on A . What are the equivalence classes of this equivalence relation when R is the preordering specified in **(i)**?

FUNCTIONS

Intuitively, a *function* from a given set A to a given set B is a device which assigns a unique element of B to each element of A . In set theory this idea is given a precise formulation in terms of *relations*. Thus we define a *function from A to B* to be a relation f between A and B possessing the following property:

for any $a \in A$, there is a *unique* $b \in B$ for which afb .

In this situation we write $f: A \rightarrow B$. A is called the *domain*, and B the *codomain*, of f . For $a \in A$, we also write $f(a)$ or fa for the unique element b of B such that afb : $f(a)$ is called the *value* of f at a , or the *image* of a under f . A function $f: A \rightarrow A$ is called a (unary) *operation* on A .

Examples. (i) The fatherhood relation F on the set H of all human beings defined by

$$aFb \Leftrightarrow b \text{ is the father of } a$$

is an operation on H .

(ii) The relation R between the set H of human beings and the set \mathbb{N} of natural numbers defined by

$$aRn \Leftrightarrow n \text{ is the number of children of } a$$

is a function from H to \mathbb{N} .

(iii) The relation R on \mathbb{N} defined by

$$mRn \Leftrightarrow n = m^2$$

is an operation on \mathbb{N} .

(iv) For any set A , the identity relation on A is an operation on A . As such, it is called the *identity operation* on A and denoted by 1_A .

It is often helpful to depict a function $f: A \rightarrow B$ by means of a "mapping" diagram like the one below:

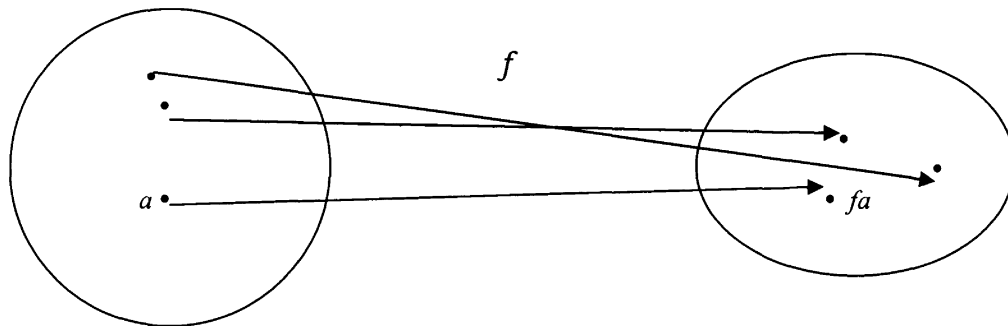

Functions or operations can have *more than one variable*. For example, the operation of addition on the set of natural numbers and the operation of conjunction on the set of all statements both involve *two variables*. Formally, an *n-ary operation* on a set A is defined to be a function $f: A^n \rightarrow A$. The value of f at an n -tuple (a_1, \dots, a_n) is written $f(a_1, \dots, a_n)$.

Exercises. 1. Let $f: A \rightarrow B$, $g: B \rightarrow C$. Prove that $g \circ f$ is a function from A to C , and that, for any x in A , $(g \circ f)(x) = g(f(x))$. Prove also that $f = 1_B \circ f = f \circ 1_A$.

2. A function $f: A \rightarrow B$ is said to be *one-to-one* if, for any x, y in A , $f(x) = f(y) \Rightarrow x = y$.

(i) Which of the functions in the examples above are one-to-one?

(ii) If $f: A \rightarrow B$ and $g: B \rightarrow C$ are both one-to-one, prove that $g \circ f$ is also.

3. Let $f: A \rightarrow B$ be a function, and X a subset of A . The *image* of X under f is the set $f[X]$ consisting of all elements of B of the form $f(x)$ with x in X . The function $f: A \rightarrow B$ is said to be *onto* B if $f[A] = B$.

(i) Draw a "mapping" diagram to illustrate $f[X]$.

(ii) If $X, Y \subseteq A$, prove that $X \subseteq Y \Rightarrow f[X] \subseteq f[Y]$.

(iii) If $X, Y \subseteq A$, prove that $f[X \cup Y] = f[X] \cup f[Y]$. Does this remain true when " \cup " is replaced by " \cap "?

(iv) If $f: A \rightarrow B$ and $g: B \rightarrow C$ are both onto, prove that $g \circ f: A \rightarrow C$ is also.

4. Let $g: A \rightarrow B$ be a function, and Y a subset of B . The *preimage* of Y under g is the set $g^{-1}[Y] = \{x: g(x) \in Y\}$.

(i) Draw a "mapping" diagram to depict $g^{-1}[Y]$.

(ii) If $Y, Z \subseteq B$, prove that $g^{-1}[Y \cup Z] = g^{-1}[Y] \cup g^{-1}[Z]$, $g^{-1}[Y \cap Z] = g^{-1}[Y] \cap g^{-1}[Z]$, and $g^{-1}[B - Y] = A - g^{-1}[Y]$.

(iii) Prove that, for any $X \subseteq A$, $X \subseteq g^{-1}[g[X]]$, and that g is one-to-one if and only if $X = g^{-1}[g[X]]$ for all $X \subseteq A$.

(iv) Prove that, for any $Y \subseteq B$, $g[g^{-1}[Y]] \subseteq Y$, and that g is onto B if and only if $g[g^{-1}[Y]] = Y$ for all $Y \subseteq B$.

Chapter II
Review of Predicate Logic

II. Review of Predicate Logic

Predicate, or quantificational logic is introduced, it will be recalled, to overcome some of the weaknesses of propositional logic. Consider, for example, the following argument:

1. *All Cretans love all animals.*
2. *All horses are animals.*
3. *Epimenides is a Cretan.*
- ∴ 4. *Someone loves all horses.*

This argument, while patently not propositionally valid, is still, given the usual reading of the terms "all" and "some", logically correct. Its correctness also of course derives from our grasp of the *grammatical structure* of the statements constituting it, which involve in an essential way *predicates* —"(is a) horse", "(is an) animal", "Cretan"—and *relations* —"loves".

In order to symbolize this argument and others like it the vocabulary of propositional logic is enlarged to that of predicate logic. Thus, as in algebra, it is natural to introduce *variables* x, y, z, \dots to refer to arbitrary individuals, and then to write, for example, " Ax " for " x is an animal", " Cx " for " x is a Cretan", " Hx " for " x is a horse", " Lxy " for " x loves y ", and " e " for "Epimenides". The symbols A, C and H are *predicate symbols*, L is a *relation symbol*, and e a *name*. Finally one introduces two symbols \forall and \exists called the *universal* and *existential quantifier*, respectively: the expression " $\forall x$ " will symbolize the phrase "for all (or any) x ", and " $\exists x$ " the phrases "for some x ", or, equivalently, "there exists x ".

To put our argument in symbolic form, the argument is first recast in the following way:

- 1'. *For any individual x , if x is a Cretan, then for any individual y , if y is an animal, then x loves y .*
- 2'. *For any individual x , if x is a horse, then x is an animal.*
- 3'. *Unchanged.*
- ∴ 4'. *For some individual x , for all individuals y , if y is a horse, then x loves y .*

Now 1'- 4' can be symbolized directly in terms of our enlarged logical vocabulary thus:

- 1". $\forall x[Cx \rightarrow \forall y(Ay \rightarrow Lxy)]$
- 2". $\forall x(Hx \rightarrow Ax)$
- 3". Ce
- 4". $\exists x\forall y(Hy \rightarrow Lxy).$

The logical system associated with the enlarged vocabulary of variables, predicate and relation symbols, names, quantifiers, as well as identity and operation symbols (see below) is called *predicate* or *quantificational logic*. Statements formulated within this vocabulary will be called *predicate* or *quantificational statements*.

TREE RULES FOR QUANTIFIERS AND IDENTITY

In order to be able to employ the tree method to test arguments within predicate logic (such as the one above) for validity we need to formulate new tree rules governing the quantifiers. In the case of \forall we shall be guided by the usual meaning of generality, namely, that whenever we assert that *all* individuals under consideration have a certain property, then, given any individual, *that* individual has, or, as we shall sometimes say, *instantiates* the property. We call this the principle of *universal instantiation*. The corresponding tree rule may be formulated thus:

- UI.** Given a statement of the form $\forall v p(v)$ occupying a node of an open path of a tree,
- (1) if a name n appears in the path, write $p(n)$ at its foot unless that statement already occupies a node of the path (in which case, writing $p(n)$ once more in the path would be redundant);
 - (2) if no name appears in the path, choose some name n and write $p(n)$ at its foot.

In writing $p(v)$ we have indicated that the statement p contains an occurrence of the variable v ; this done, we have written $p(n)$ for the result of substituting " n " for " v " at each occurrence of the latter in p .¹

We now require a rule for the existential quantifier. This is the rule of *existential instantiation*:

¹ Strictly speaking, by "occurrence of v " here we mean *free* occurrence, that is, an occurrence of v *not* within a context of the form " $\forall v q(v)$ " or " $\exists v q(v)$ ". We shall always tacitly assume that this is the kind of occurrence in question.

EI Given an statement of the form $\exists v p(v)$ occupying a node of an open path, check to see whether it contains a node occupied by a statement of the form $p(n)$. If not, choose a name n *that has not been used anywhere in the path* and write the statement $p(n)$ at its foot.

$$\begin{array}{c} \exists v p(v) \\ | \\ p(n) \quad (n \text{ new}) \end{array}$$

It is important to observe in applying this rule that the name n introduced *not be already present in the path*. This is imperative because we want n to name an individual *about which we assume nothing except that it satisfy p* ; individuals that have already been named may have properties that conflict with this supposition.

The last rule governing the quantifiers is the

RULE FOR NEGATED QUANTIFICATION

If a statement beginning with $\neg\forall v$ (or $\neg\exists v$) occupies a node of an open path, write at the feet of all open paths containing that node the same statement with $\exists v\neg$ in place of $\neg\forall v$ (or with $\forall v\neg$ in place of $\neg\exists v$) in front.

$$\begin{array}{cc} \neg\forall v p(v) & \neg\exists v p(v) \\ \exists v\neg p(v) & \forall v\neg p(v) \end{array}$$

In predicate logic we can also make assertions of *identity* or *equality* using the identity symbol $=$ and the nonidentity symbol \neq . Identity statements are governed by the following tree rules:

RULE FOR IDENTITY

If an open path contains a full line of the form $m = n$ and also a full line p in which one of the names m, n appears one or more times, write at the foot of the path a statement q obtained by replacing one or more of the occurrences of that name in p by the other name, provided that q does not already appear in that path as a full line:

$$\begin{array}{c} m = n \\ p \\ | \\ q \end{array}$$

RULE FOR NONIDENTITY (OR DIVERSITY)

Close any path that contains a line of the form $n \neq n$:

$$\begin{array}{c} n \neq n \\ \times \end{array}$$

We note that the identity rules enable us to establish the *four basic laws of identity*, viz., *substitutivity, reflexivity, symmetry, and transitivity*.

Substitutivity

$$\begin{array}{c} p(a) \\ \underline{a = b} \\ p(b) \end{array}$$

The validity of this inference is confirmed by the fact that the following tree closes:

$$\begin{array}{c} p(a) \\ a = b \end{array}$$

$$\begin{array}{l} \neg p(b) \\ p(b) \\ \times \end{array}$$

where we have used the rule for identity to obtain the fourth line from the first two.

Reflexivity

$$\frac{}{a = a}$$

The validity of this inference follows immediately from the rule for nonidentity.

Symmetry

$$\frac{a = b}{b = a}$$

The correctness of this inference follows from the closed tree

$$\begin{array}{l} a = b \\ b \neq a \\ b \neq b \\ \times \end{array}$$

in which the third statement is obtained from the first two by the rule for identity, and closure from the rule for nonidentity.

Transitivity

$$\frac{a = b \quad b = c}{a = c}$$

The correctness of this inference results from the fact that the following tree is closed:

$$\begin{array}{l} a = b \\ b = c \\ a \neq c \\ a \neq b \\ \times \end{array}$$

where the last statement arises from the second and third by the rule for identity.

VALIDITY AND INTERPRETATIONS

The reader will observe that we have been calling an argument formulated in predicate logic *valid*, or *correct*, if the tree beginning with the argument's premises and negated conclusion closes. In consonance with this, we call a predicate statement *valid* if the tree starting with its negation closes. Further, we say that a set of predicate statements is *satisfiable* or *consistent* if any tree starting with that set of statements contains an open path. Now these are, of course, purely *formal* definitions in which, by contrast with the corresponding definitions for propositional logic, the concepts of truth and falsity do not figure. Nevertheless, with a little insight it is possible to reformulate these definitions for predicate statements in terms of truth and falsity. We give a brief outline.

The central idea we need is that of an *interpretation* of the vocabulary of predicate logic, a concept which generalizes that of a valuation of statement letters. For this purpose we shall allow our logical vocabulary to include, in addition to names and predicate symbols, relation symbols linking an arbitrary number of individuals: thus relation symbols may be binary, ternary, ..., n -ary. An *interpretation* \mathbf{I} of our logical vocabulary now consists of:

- (i)** A *nonempty set* A called the *domain or universe* of \mathbf{I} .
- (ii)** To each *name* a , an assignment of a definite *element* of A , denoted by $a^{\mathbf{I}}$, and called the *interpretation under* \mathbf{I} of that name.
- (iii)** To each *predicate symbol* P , an assignment of a definite *subset* of A , denoted by $P^{\mathbf{I}}$, and called the *interpretation under* \mathbf{I} of that predicate symbol.
- (iv)** To each *n -ary relation symbol* R , an assignment of a definite *n -ary relation* on A (i.e., a subset of A^n), denoted by $R^{\mathbf{I}}$, and called the *interpretation under* \mathbf{I} of that relation symbol.

Once an interpretation of our logical vocabulary has been fixed, it becomes possible to assign a definite *truth value* to each statement based on that vocabulary by giving the identity symbol, the logical operators, and the quantifiers, their natural meanings. This is best conveyed by an example.

Suppose our vocabulary contains one binary relation symbol L and one

name a . Consider the interpretation \mathbf{I} whose universe is the set of natural numbers $\{1,2,3,\dots\}$, a is interpreted as the number 1, and L is interpreted as the "less than" relation $<$. Let us determine the truth values of the statements

$$(1) \exists x Lax \quad (2) \forall x Lax \quad (3) \forall x \exists y Lxy \quad (4) \forall x \exists y (x \neq y)$$

under \mathbf{I} . To do this we use \mathbf{I} to "translate" these statements into assertions possessing truth values as follows. The "translation" of (1) is:

"There is a number x such that $1 < x$ "

which is obviously *true*. The "translation" of (2) is

"For all numbers x , $1 < x$ ",

which is clearly *false* since it is not the case that $1 < 1$. The "translation" of (3) is

"For any number x , there is some number y such that $x < y$ ",

which is obviously *true*. And finally, the "translation" of (4) is

"For any number x , there is a number y unequal to x ",

which is, again, obviously *true*.

This example indicates the method by which any interpretation can be made to yield a definite truth value—truth or falsity—to each predicate statement p : we call this the *truth value of p under \mathbf{I}* .

An argument or inference \mathbf{A} formulated within predicate logic is said to be *valid* if, for any interpretation \mathbf{I} of its vocabulary, whenever all the premises of \mathbf{A} are true under \mathbf{I} , so is its conclusion. In that case, we say that the conclusion is a *logical consequence* of the premises. A *sentence* is said to be *logically valid* if it is true under *any* interpretation. A set S of sentences is said to be *satisfiable* or *consistent* if there is an interpretation under which all the sentences in S are true: such an interpretation is called a *model* of S . A sentence p is said to be *independent* of a set of sentences S if there is an interpretation under which each sentence in S is true but p is false.

Examples. 1. The sentence

$$(1) \quad \forall y \exists x Rxy$$

is a logical consequence of the sentence

$$(2) \quad \exists x \forall y Rxy.$$

Now, given an interpretation \mathbf{I} , with domain A , the “translation” of sentence (1) is

$$(1') \quad \text{“for all } y \in A \text{ there exists } x \in A \text{ such that } R^{\mathbf{I}}xy\text{”}$$

and that of (2) is

$$(2') \quad \text{“there exists } x \in A \text{ such that, for all } y \in A, R^{\mathbf{I}}xy\text{”}.$$

If (2') is true, we may pick $a \in A$ so that

$$(3) \quad \text{“for all } y \in A, R^{\mathbf{I}}ay\text{”}$$

is true. But the truth of (3) obviously implies that of (1'). Thus the truth of (2) under the arbitrary interpretation \mathbf{I} implies that of (1) and so (1) is a logical consequence of (2).

2. The sentence

$$(5) \quad \exists y \forall x Rxy$$

is *not* a logical consequence of the sentence

$$(6) \quad \forall x \exists y Rxy.$$

For consider the interpretation \mathbf{I} with domain \mathbb{N} , the set of natural numbers, in which $R^{\mathbf{I}}$ is $<$, the “less than” relation. Then the “translation” of (6) under \mathbf{I} is

$$\text{“for any } x \in \mathbb{N}, \text{ there exists } y \in \mathbb{N} \text{ such that } x < y\text{”},$$

which is evidently true. On the other hand the “translation” of sentence (5) under \mathbf{I} is:

“there exists $y \in \mathbb{N}$ such that, for all x in \mathbb{N} , $x < y$,

which is evidently false (since there is no greatest number). It follows that (5) is not a logical consequence of (6), or, in other words, (5) is independent of (6).

Exercises. 1. Prove that the following inferences are valid using the method just described. **(i)** $\forall x(Px \vee Qx), \exists xPx \rightarrow \forall x(Sx \vee Tx), \neg \forall xQx, \neg \forall xSx. \therefore \exists xTx$.

(ii) $\forall xPx, \forall xQx. \therefore \forall x(Px \wedge Qx)$. **(iii)** $\forall xPx \rightarrow \forall xQx. \therefore \exists x \forall y(Px \rightarrow Qy)$.

2. Establish the logical validity of the following sentences. **(i)** $\neg \forall xPx \leftrightarrow \exists x \neg Px$, **(ii)** $\neg \exists xPx \leftrightarrow \forall x \neg Px$.

3. Let p be a sentence and Q a predicate. Establish the logical validity of the following sentences. **(i)** $\forall x(p \wedge Qx) \leftrightarrow (p \wedge \forall xQx)$, **(ii)** $\forall x(p \vee Qx) \leftrightarrow p \vee \forall xQx$, **(iii)** $\exists x(p \wedge Qx) \leftrightarrow (p \wedge \exists xQx)$, **(iv)** $\exists x(p \vee Qx) \leftrightarrow (p \vee \exists xQx)$, **(v)** $\forall x(p \rightarrow Qx) \leftrightarrow (p \rightarrow \forall xQx)$, **(vi)** $\forall x(Qx \rightarrow p) \leftrightarrow (\exists xQx \rightarrow p)$, **(vii)** $\exists x(p \rightarrow Qx) \leftrightarrow (p \rightarrow \exists xQx)$, **(viii)** $\exists x(Qx \rightarrow p) \rightarrow (\forall xQx \rightarrow p)$.

4. Determine which of the following sentences are logically valid. For each sentence which is not logically valid, provide an interpretation in which it is false. **(i)** $\exists x(Px \rightarrow \forall yPy)$, **(ii)** $\forall x \forall y \forall z[(Rxy \wedge Ryz) \rightarrow Rxz]$, **(iii)** $(\exists xPx \wedge \exists xQx) \rightarrow$

$\exists x(Px \wedge Qx)$, **(iv)** $\forall x(Px \vee Qx) \rightarrow (\forall xPx \vee \forall xQx)$.

5. Which of the following sets of sentences are satisfiable? In each of the satisfiable cases, supply an interpretation under which all of the sentences are true. **(i)** $\forall xPx, \forall x[Px \rightarrow \exists yRxy], \exists x \exists y \neg Rxy$. **(ii)** $\forall x \exists y Rxy, \forall x \exists y \neg Rxy$. **(iii)** $\forall x \neg Rxx, \forall x \forall y \forall z[(Rxy \wedge Ryz) \rightarrow Rxz], \exists x \exists y \exists z(Rxy \wedge Ryz \wedge Rzx)$.

6. Prove that the statement $\exists x[Px \wedge \forall y(Py \rightarrow y = x)]$ is true under an interpretation **I** if and only if the set P^I contains exactly one element. Formulate statements which are true under an arbitrary interpretation **I** if and only if P^I contains **(i)** at most one element, **(ii)** at most two elements, **(iii)** at least two elements, **(iv)** exactly two elements, **(v)** at most three elements, **(vi)** at least three elements, **(vii)** exactly three elements.

Recall that the concepts of validity and consistency were originally defined in terms of *trees*: an argument was deemed *valid* if its associated tree closes, and a set of sentences *consistent* if any tree with that set as initial statements contains at least one open path. It can be shown (although we shall not do so here) that—just as for propositional logic—the two versions of validity and the two versions of consistency are *equivalent*. We shall in fact only make use of the equivalence of the two notions of validity.

OPERATION SYMBOLS

We recall that an n -ary *operation* on a set A is a function from A^n to A . It is helpful to enlarge the vocabulary of predicate logic to include symbols—*operation* (or *function*) *symbols*—which will be interpreted as operations on the domain of a given interpretation.

Accordingly we now suppose that in addition to names, predicate symbols and relation symbols, our logical vocabulary includes *operation symbols* f, g, h, \dots . Each such symbol is assigned a number $n \geq 1$ called its *multiplicity*. An operation symbol of multiplicity n will be said to be n -ary. We now define the *terms* based on this of this enlarged vocabulary.

- (i) Any name standing alone is a term.
- (ii) If f is an n -ary operation symbol, and t_1, \dots, t_n are n terms, then $f t_1 \dots t_n$ is a term.

In this enlarged vocabulary, a *name* will now be any term *which does not contain variables*, and a *simple name* will be a name in the original sense, i.e., a name that does not contain operation symbols.

We also extend the idea of an *interpretation* to operation symbols and names in the enlarged sense by the clause:

An interpretation \mathbf{I} with domain A assigns, to each n -ary operation symbol f , an n -ary operation $f^{\mathbf{I}}$ on A . If t_1, \dots, t_n are names, and f an n -ary operation symbol, $(f t_1 \dots t_n)^{\mathbf{I}} = f^{\mathbf{I}}(t_1^{\mathbf{I}} \dots t_n^{\mathbf{I}})$.

Example. Suppose our logical vocabulary has one predicate symbol P , one relation symbol R , two unary (i.e., 1-ary) operation symbols f, g , and two simple names m, n . Let \mathbf{I} be the interpretation of this vocabulary whose domain is the set H of human beings and in which the interpretation of P is the set of females, that of R is the parenthood relation, that is, the set of pairs (x, y) for which x is a parent of y , and those of f/g are the operation on H assigning to each human being his or her father/mother. The interpretations of m and n will be two arbitrary but fixed human beings a and b .

Then, for example, the sentence

$$m = gfn$$

is true under I just when a is b 's paternal grandmother. And the sentence

$$m \neq n \wedge Rfmn \wedge Rgmn \wedge Pm$$

is true just when a is b 's sister.

Operation symbols may also be employed in trees. However, in doing this we must at the same time insist that when the **EI** rule requires us to introduce a new name, it must be a *simple* one.

Exercises. 1. In each case write down a sentence in logical vocabulary which is true under the above interpretation I precisely when: **(i)** a is a grandmother of b , **(ii)** a is a father, **(iii)** a is a maternal aunt of b , **(iv)** a is a grandfather, **(v)** a and b are full siblings, **(vi)** a and b are full or half siblings.

2. In each case compose a concise English sentence which is true just when each one of the following sentences is true under I : **(i)** $m \neq n \wedge fm = fn \wedge gm = gn$, **(ii)** $fm = fn \leftrightarrow gm \neq gn$, **(iii)** $\exists x(Rxm \wedge fn = fx \wedge gn = gx)$, **(iv)** $\neg Pn \wedge \neg Rnm \wedge \exists x(Rxm \wedge Rfnx \wedge Rgnx)$.

Chapter III
Postulate Systems for Arithmetic

III. Postulate Systems for Arithmetic

Mathematical concepts are often presented by means of *postulates* (sometimes called *axioms*) formulated as sentences of predicate logic. In writing such sentences it is customary to place binary operation symbols between arguments, rather than in front of them: thus, for example, one writes $x + y$ instead of $+xy$.

The logical vocabulary for *arithmetic* includes a unary operation symbol s , two binary operation symbols $+$ and \times , and a name 0 . The *standard interpretation* **N** of this vocabulary is the familiar *natural number system*, specified as follows:

Domain: the set $= \{0, 1, 2, \dots\}$ of natural numbers

Interpretation of s : the (immediate) successor operation $_ + 1$

Interpretation of $+$ and \times : the usual operations of addition and multiplication

Interpretation of 0 : the number zero.

Thus the domain and successor operation of the standard interpretation may be represented by the following *diagram*:



in which each arrow proceeds from an element to its successor.

The postulates for *basic arithmetic* are the following:

B1	$\forall x \forall y (x \neq y \rightarrow sx \neq sy)$
B2	$\forall x \quad 0 \neq sx$
B3	$\forall x (x \neq 0 \rightarrow \exists y (x = sy))$
B4	$\forall x \quad x + 0 = x$
B5	$\forall x \forall y \quad x + sy = s(x + y)$
B6	$\forall x \quad x \times 0 = 0$
B7	$\forall x \forall y \quad x \times sy = (x \times y) + x.$

These postulates are all true in the standard interpretation. The first three express familiar facts about the successor operation:

- B1** *Distinct natural numbers have distinct successors.*
B2 *Zero is the successor of no natural number.*
B3 *Every nonzero natural number is a successor.*

The next two postulates tell us how to add in this notation:

- B4** *Adding 0 has no effect.*
B5 $(x + y) + 1 = x + (y + 1)$.

In this notation each *numeral* 1, 2, 3, 4,... is represented by a string of s's of the appropriate length followed by 0, as in

$$1 = s0 \quad 2 = ss0 \quad 3 = sss0 \quad 4 = ssss0, \dots$$

Here is a tree justifying the inference of $2 + 2 = 4$ from **B4** and **B5**:

(1)	$\forall x \quad x + 0 = x$	
(2)	$\forall x \forall y \quad x + sy = s(x + y)$	
(3)	$\neg(ss0 + ss0 = ssss0)$	
(4)	$ss0 + 0 = ss0$	from (1)
(5)	$ss0 + s0 = s(ss0 + 0)$	from (2)
(6)	$ss0 + ss0 = s(ss0 + s0)$	from (2)
(7)	$ss0 + ss0 = ss(ss0 + 0)$	from (5) and (6)
	$ss0 + ss0 = ssss0$	from (7) and (4)
	x	

Finally, the two remaining postulates reduce multiplication to repeated addition:

- B6** *Multiplying by 0 yields 0.*
B7 $x \times (y + 1) = (x \times y) + x$.

Exercise. Using the tree test, show that the arguments from one or more of the postulates of basic arithmetic to the following sentences are valid: **(i)** $0 \neq s0$, **(ii)** $s0 \neq ss0$, **(iii)** $0 \neq ssss0$, **(iv)** $ss0 \neq ssss0$, **(v)** $0 + ss0 = ss0$, **(vi)** $0 \times ss0 = 0$.

Basic arithmetic has a property known as *incompleteness*. By this is meant that there are certain sentences true in the standard interpretation (the natural number system) which are *independent* of basic arithmetic. For instance, although each of the sentences

$$0 \neq s0, s0 \neq ss0, ss0 \neq ssss0, \dots$$

is provable in basic arithmetic (the first two are (i) and (ii) of the exercise immediately above), the corresponding generalization

(a)
$$\forall x \quad x \neq sx$$

is *not*. Similarly, *none* of the following generalizations are deducible in basic arithmetic, even though all their particular instances are:

(b)
$$\forall x \quad 0 + x = x$$

 (c)
$$\forall x \forall y \forall z \quad x + (y + z) = (x + y) + z$$

 (d)
$$\forall x \forall y \quad x + y = y + x$$

 (e)
$$\forall x \quad 0 \times x = 0$$

 (f)
$$\forall x \forall y \quad sx \times y = (x \times y) + y$$

 (g)
$$\forall x \forall y \quad x \times y = y \times x$$

To establish the independence of (a) - (g) from the postulates of basic arithmetic, we must supply a model of basic arithmetic, that is, an interpretation in which **B1 - B7** are true, but in which (a) - (g) are *false*. It is easy to check that the following interpretation **J** does the job:

Domain: the natural numbers together with two additional distinct objects \$,@

Interpretation of s: indicated by the diagram below, in which each arrow leads from a member of the domain to its successor:

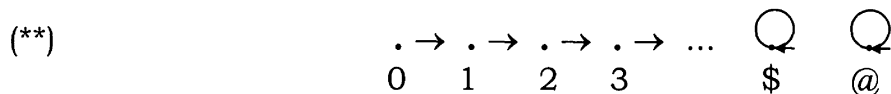

Interpretation of + and ×: as usual when the arguments are both natural numbers. When one or both arguments are \$ or @, the values are given by the tables below, in which n is any natural number, and $n^>$ is any nonzero natural number:

+	n	\$	@	×	0	$n^>$	\$	@
n		@	\$	n			\$	@
\$	\$	@	\$	\$	0	@	@	@
@	@	@	\$	@	0	\$	\$	\$

The incompleteness of basic arithmetic implies that it also fails to be *categorical*. A set of postulates is said to be *categorical* if all of its models are *isomorphic* (Greek *iso*: "same", *morphe*: "form") in the sense that the *same* diagram serves for all of them, apart from the relabelling of nodes. The noncategoricity of basic arithmetic can be seen immediately from the fact that the standard interpretation **N** is not isomorphic to the interpretation **J** defined above. For no relabelling of nodes can ever convert **N**'s diagram (*) into **J**'s diagram (**), since the latter contains loops and the former doesn't.

Incompleteness of basic arithmetic is a kind of deductive weakness: certain sentences that one would expect to be able to prove turn out not to be provable. This weakness can be to a great extent overcome by adding to it a new rule known as the *principle of mathematical induction*. Informally, this is the rule of arithmetic which states:

for any property P of natural numbers, if P_0 , and if, for any number n , $P(n+1)$ follows from P_n , then every number has the property P.

It follows from this that, if P is a property of natural numbers such that P_0 is true but P_a is false for some number a , then there must be *some* number n for which $P(n + 1)$ does not follow from P_n , that is, for which P_n is *true* but $P(n + 1)$ is *false*. It is this consequence that we express in the form of the new tree rule:

MI
 $p(0)$
 $p(t)$
 \mid
 $p(b)$
 $\neg p(sb)$

Here $p(t)$ is any sentence containing occurrences of the name t , b is a new simple name, and $p(0)$, $p(b)$ are the sentences obtained by substituting 0 , b , respectively, for each occurrence of t in $p(t)$. This rule is clearly sound in the standard interpretation.

Let us show that sentence (a) above follows from **B1** and **B2** when we are allowed to use rule **MI**. Here is the appropriate closed tree:

$$\begin{array}{c}
 \forall x \forall y (x \neq y \rightarrow sx \neq sy) \\
 \forall x \quad 0 \neq sx \\
 \neg \forall x \quad x \neq sx \\
 | \\
 0 \neq s0 \\
 | \\
 \neg(a \neq sa) \\
 | \\
 (*) \quad b \neq sb \\
 \neg(sb \neq ssb) \\
 | \\
 b \neq sb \rightarrow sb \neq ssb \\
 \swarrow \quad \searrow \\
 \neg(b \neq sb) \quad sb \neq ssb \\
 \times \qquad \qquad \times
 \end{array}$$

Here to obtain the sentences at (*) we applied **MI** to the two sentences immediately above, with $p(t)$ the sentence $\neg(t = st)$.

Exercises. 1. Show that **MI** is *unsound* in the interpretation **J** of basic arithmetic given above. That is, find a sentence p for which the premises of **MI** are true under **J**, but the sentences forming the conclusion cannot be simultaneously true. (Hint: consider the sentence $a \neq sa$.)

2. Use **MI** to derive sentences (b) and (e) above from (some of) the postulates of basic arithmetic.

3. Derive the following inference form from **MI**:

$$\frac{p(0) \quad \forall x [p(x) \rightarrow p(sx)]}{\forall x p(x)}$$

4. Consider the following "rule" ("the ω -rule"):

$$\begin{array}{c}
 p(0) \\
 p(s0) \\
 p(ss0) \\
 \vdots \\
 \hline
 \vdots \\
 \forall x p(x)
 \end{array}$$

This rule stipulates that a universal generalization follows from the infinite set of premises consisting of its instances for all numeral values of the universally generalized variable. It is an *infinitary* rule allowing an infinite branch to close. The rule is clearly sound for the standard interpretation.

- (i) Show that the ω -rule is unsound for the interpretation \mathcal{J} above.
- (ii) Sketch the general appearance of trees, using the ω -rule but not **MI**, for the inference of sentence (a) above from **B1** and **B2**, and sentence (b) above from **B1**, **B2**, **B4** and **B5**.

Chapter IV
Second-Order Logic

IV. Second-Order Logic

Predicate logic is often known as *first-order* logic, because in forming its sentences quantification is restricted to individuals, that is, *first-order* entities. *Second-order* logic is an extension of first-order logic which allows existential and universal quantification of *second-order* entities such as predicates, relations, and operations. As examples of second-order sentences we have:

$$(1) \quad \forall x \forall y [x = y \leftrightarrow \forall P (Px \rightarrow Py)] \qquad (2) \quad \forall x \forall y \exists R Rxy.$$

The first of these asserts that individuals are identical just when one possesses every property the other does, and the second that any two individuals are related in some way or other. In these sentences the letter "P" is used as a one-place predicate variable, for properties of individuals, and the letter "R" is used as a binary relation variable, for relations between individuals.

Another example is the sentence

$$(3) \qquad \qquad \qquad \forall P [(P0 \wedge \forall x (Px \rightarrow Psx)] \rightarrow \forall x Px],$$

which expresses the *principle of mathematical induction* stated in the previous chapter.

The formation and interpretation rules for sentences of second-order logic are straightforward extensions of the corresponding first-order rules. One needs to note only that, in the second-order case, a *name* can now be a predicate, relation, or operation symbol, or an expression that, as in the examples above, can be construed as one. An interpretation of such a name is then a predicate, relation (of the appropriate number of argument places) or operation on the domain of the interpretation. The notions of *validity*, *consistency* and *model* are thus automatically extended to second-order sentences.

The *tree method* can be applied to reasoning involving second-order sentences —*second-order reasoning*— in essentially the same way as for first-order reasoning. For instance, let us apply the tree test for validity to the sentence (1) above. We get the tree below, in which the vertical lines have been omitted.

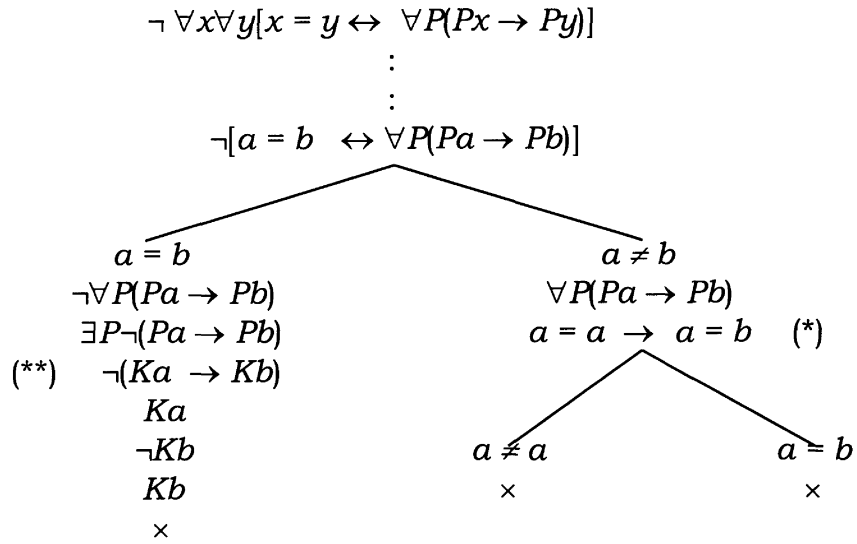

To obtain line (*) we applied **UI** (extended in the obvious way to second-order sentences) to the sentence $\forall P(Pa \rightarrow Pb)$ immediately above by choosing the instance of the predicate variable "P" to be the expression " $a =$ ", that is, the property of *being a*. To obtain line (**) we applied **EI** (extended in the obvious way to second-order sentences) to the sentence $\exists P \neg(Pa \rightarrow Pb)$ immediately above by introducing a *new predicate name K* and substituting it for P. The tree is then seen to close, so that the sentence in question is a logical truth. This means, in effect, that in second-order logic identity $x = y$ can be defined as $\forall P(Px \rightarrow Py)$.

Similarly, in the case of sentence (2), we get the tree

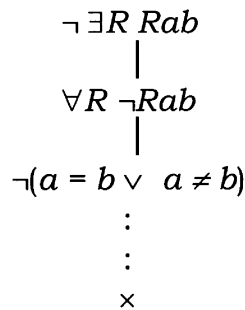

where the last line is obtained from second-order **UI** by choosing for R the relation $x = y \vee x \neq y$.

Exercise. Using the tree method as above, show that the following arguments are valid: **(i)** $\forall P(Pa \rightarrow Pb), \forall P(Pb \rightarrow Pc). \therefore \forall P(Pa \rightarrow Pc)$, **(ii)** $\forall P(Pa \rightarrow Pb) \therefore \forall P(Pb \rightarrow Pa)$.

We have seen that *basic arithmetic* has models that differ in essential respects from the standard interpretation—the natural number system. Sentence (3) above—the *principle of mathematical induction*—is a second-order sentence which is true in the standard interpretation, and, in a certain sense, *only* in that interpretation. The first, and crucial, step in demonstrating this is to establish what we shall call the

Exhaustion principle. Models of the principle of mathematical induction are exactly those interpretations in which (the interpretations of the names on) the list $0, s0, ss0, sss0, \dots$ exhausts the whole domain of the interpretation.

To see this, suppose that \mathbf{I} is a model of the principle. Then if L is (a name for) the property of being the interpretation under \mathbf{I} of a name on the list, clearly $L0$ and $\forall x(Lx \rightarrow Lsx)$ are both true under \mathbf{I} . Since the induction principle has been assumed to be true under \mathbf{I} , so then will the sentence $\forall xLx$. But the truth of this means precisely that every individual in the domain is named on the list.

Conversely, suppose that the domain of an interpretation \mathbf{I} consists exactly of (the interpretations of) $0, s0, ss0, sss0, \dots$. Let P be (a name for) any predicate defined on the domain of \mathbf{I} , and assume that $P0$ and $\forall x(Px \rightarrow Psx)$ are both true under \mathbf{I} . We claim that $\forall xPx$ is also true under \mathbf{I} . If not, then some element of the domain fails to satisfy P . This element cannot be (the interpretation of) 0 , and must therefore be (the interpretation of) s^n0 for some $n \geq 1$ (here s^n0 is 0 preceded by n s's). Choosing n to be least, we have $n \geq 1$ and $Ps^{n-1}0$ is true under \mathbf{I} . Since $\forall x(Px \rightarrow Psx)$ is true under \mathbf{I} , it follows that $Ps^{n-1}0 \rightarrow Ps^n0$ is true under \mathbf{I} , and hence Ps^n0 is also true under \mathbf{I} . This contradiction shows that $\forall xPx$ must have been true under \mathbf{I} after all. Accordingly

$$P0 \wedge \forall x(Px \rightarrow Psx) \rightarrow \forall xPx$$

is true under \mathbf{I} ; since P was arbitrary, we conclude that the induction principle is true under \mathbf{I} .

It follows immediately from the exhaustion principle that in any model of the induction principle the postulate

$$\mathbf{B3} \quad \forall x(x \neq 0 \rightarrow \exists y(x = sy))$$

of basic arithmetic must also be true. In fact this postulate is derivable from the induction principle, as the following closed tree demonstrates. Here we use " $S(x)$ " as an abbreviation for " $x \neq 0 \rightarrow \exists y(x = sy)$."

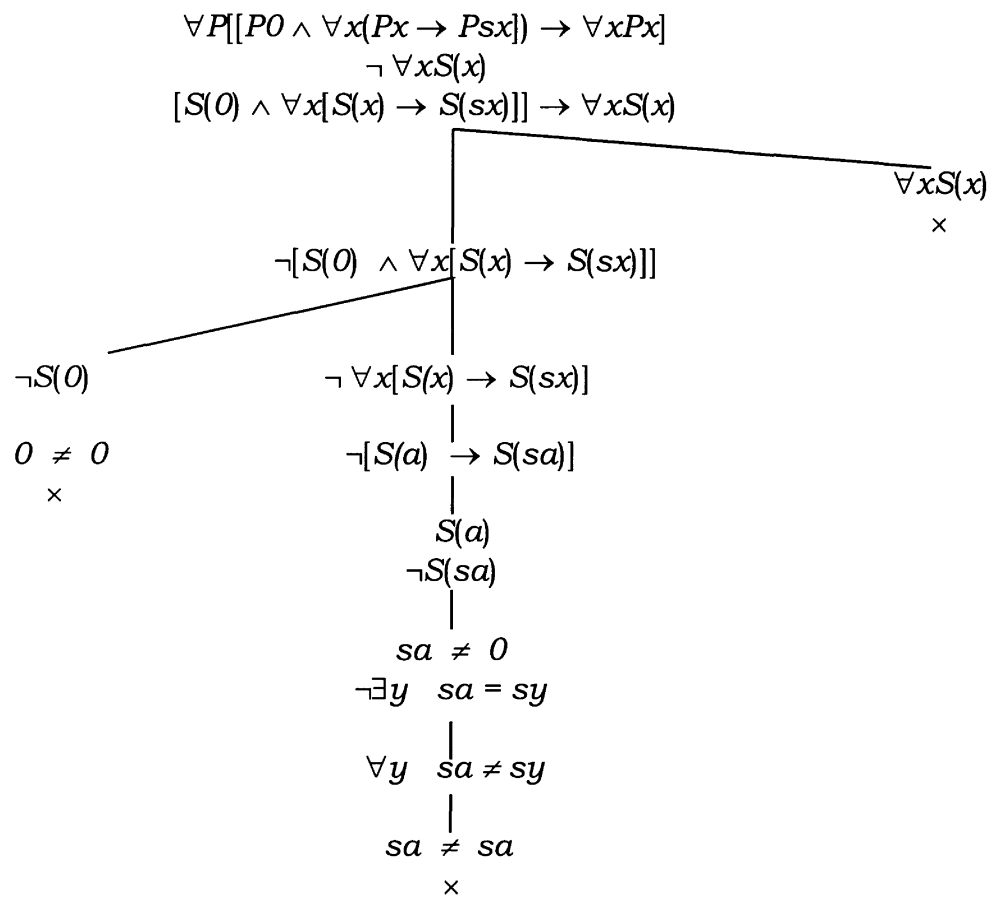

The second order induction principle has several nonisomorphic models, which shows that, taken by itself, it is not categorical. These models are based on the four diagrams below, in which the interpretations of s and 0 are displayed: as usual, each arrow goes from an element to its "successor".

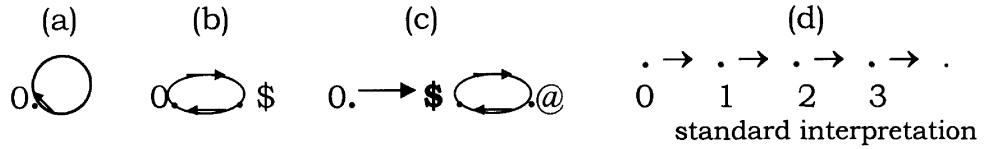

It is evident that no one of these diagrams can be converted into another by relabelling nodes, since they all contain different numbers of nodes: 1, 2, 3, infinity. The interpretations are therefore nonisomorphic.

Exercise. Show that the induction principle is true in each of the interpretations whose diagrammed by (a) (b) and (c) (and of course (d)).

In contrast, the system—known as *second-order arithmetic*—obtained by adding postulates

$$\begin{array}{ll} \mathbf{B1} & \forall x \forall y (x \neq y \rightarrow sx \neq sy) \\ \mathbf{B2} & \forall x \quad 0 \neq sx \end{array}$$

to the second-order induction principle *is* categorical, as we shall shortly establish.

Exercise. Show that **B1** is false in interpretation (c), and **B2** is false in both (a) and (b).

Second-order arithmetic is categorical: any interpretation **I** in which **B1**, **B2** and the second-order induction principle are all true is isomorphic to the standard interpretation **N**.

To prove this, we first note that, by the exhaustion principle, the domain of **I** consists of the interpretations of the names on the list

$$(*) \quad 0, s0, ss0, sss0, \dots$$

The truth of **B2** under **I** means that the sentences $0 \neq s0$, $0 \neq ss0$, $0 \neq sss0$ are all true under **I**. The truth of **B1** under **I** now implies that distinct members of the list (*) receive distinct interpretations under **I**. (For if not, then, for example, $sss0 = sssss0$ would be true under **I** and three applications of **B1** would show $0 = ss0$ to be true under **I**, contradicting what we have already established.) It follows that the diagram of **I** looks like:

$$\begin{array}{ccccccc} \cdot & \rightarrow & \cdot & \rightarrow & \cdot & \rightarrow & \cdot & \rightarrow \dots \\ 0 & & s0 & & ss0 & & sss0 & \end{array}$$

Clearly this diagram can be relabelled so as to convert it into the diagram of the standard interpretation \mathbf{N} , viz.,

$$\begin{array}{ccccccc} \cdot & \rightarrow & \cdot & \rightarrow & \cdot & \rightarrow & \cdot & \rightarrow \dots \\ 0 & & 1 & & 2 & & 3 & \end{array}$$

Therefore \mathbf{I} and \mathbf{N} are isomorphic.

The categoricity of second-order arithmetic means that—unlike basic arithmetic—it furnishes a *complete characterization* of the natural numbers with the successor function in the following sense:

For any sentence p in the vocabulary of second-order arithmetic, p is a logical consequence of second-order arithmetic if and only if p is true in the standard interpretation \mathbf{N} .

To prove this, we observe that if p is a logical consequence of second-order arithmetic, it must be true in every model of it, and so in particular it must be true in \mathbf{N} . Conversely, suppose p is true in \mathbf{N} , and let \mathbf{I} be any model of second-order arithmetic. Since second-order arithmetic is categorical, \mathbf{I} is isomorphic to \mathbf{N} , so since p is true in \mathbf{N} , it must also be true in \mathbf{I} . Therefore p is a logical consequence of second-order arithmetic.

Chapter V
Contextual (Modal) Logic

V. Contextual (Modal) Logic

In classical propositional logic we think of a statement as being simply true or false, with no reference to context. In *contextual logic*, on the other hand, we are concerned with statements whose truth is in some way *context dependent*. For instance,

it is raining here

is a context-dependent statement of the kind we have in mind: its truth depends on the exact location of "here", which, accordingly, plays the role of the context.

Another example of a context dependent statement is

it is raining over a 10 square mile circular region centred 50 miles north of here.

There is a connection between these two types of statement. Let us write simply p for the partial statement *it is raining*. Then *it is raining at (place) x* is the same as

p holds at x .

Given a place x , call any place y within a 10 square mile circular region centred 50 miles north of x a *place of relevance to x* and the set of such places the *region of relevance determined by x* : it will of course vary with x . We agree to write $\Box p$ (read "box p ") for the partial statement *it is raining over a region of relevance*. In that case, the statement

it is raining over a 10 square mile circular region centred 50 miles north of x

may be written

$\Box p$ holds at x .

Similarly, if we agree to write $\Diamond p$ (read "diamond p ") for the partial statement

it is raining at a place of relevance,

then the statement

it is raining somewhere within a 10 square mile circular region centred 50 miles north of x

may be written

$\diamond p$ holds at x .

Clearly we have

$$\neg \diamond p \Leftrightarrow \Box \neg p \quad \text{and} \quad \neg \Box p \Leftrightarrow \diamond \neg p.$$

The symbols \Box and \diamond are *operators*, which, like \neg , when applied to a propositional statement (such as "it is raining") yield new propositional statements. They are called *contextual* or *modal* operators. Thus the class of *contextual (propositional) statements* is defined by adding to the formation rules for propositional statements the clause:

if p is a statement, so are $\Box p$ and $\diamond p$.

As indicated by the example above, we think of the truth values of contextual statements as being implicitly determined by *contexts*. This idea leads us to adopt the following *tree rules* for contextual statements. First, the

\diamond rule
$\diamond p$
<hr style="width: 50%; margin: 0 auto;"/>
p

This may be read: *if $\diamond p$ occurs in a tree, a new context may be introduced immediately below and p asserted there..*

Here we have incorporated a new device into our trees, namely that of introducing or moving to a *new context*. We will indicate a change of context by means of a solid horizontal line: thus two statements in a given path not separated by a horizontal line are said to be in the *same context*: it follows that a tree containing n horizontal lines contains $n + 1$ contexts. It is important to understand that each application of the \diamond rule to statements appearing in the same context *requires the introduction of a separate and independent new context*. This is illustrated by the following example:

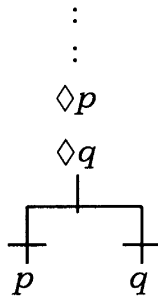

Here it must be noted that *the fork* $\begin{array}{c} | \\ \hline \vdash \quad \vdash \end{array}$ *does not indicate the splitting of the given path into two paths*; it signifies merely the introduction of two independent contexts *within a single path*.

Our second new rule is the

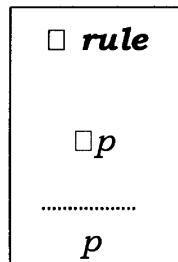

This may be read: *if $\square p$ occurs in a given context, and a new context is introduced just below that context, then p may be asserted there.*

Note that in presenting these rules a solid line will indicate that it is permissible to introduce a new context, while a broken line means only that if *some other rule* allows us to introduce a new context, then the rule in question allows us to assert something in it.

We also adopt the

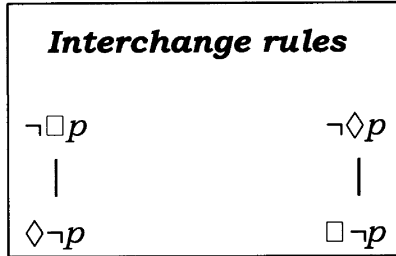

Finally, we declare a path to be *closed* only when it contains some statement and its negation *not separated by a horizontal line*, that is, within the same context. As usual, a tree is said to be *closed* if all its paths are closed.

In the case of a path containing a fork, e.g.

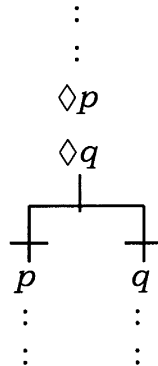

the path closes provided *at least one* of the subpaths starting with p or q closes.

We write \blacksquare for the system of tree rules consisting of the rules for the propositional operators, the \Box - and \Diamond - rules, the interchange rules, and the new rule for closing a path. This system is called *basic contextual logic*. A tree constructed in accordance with the \blacksquare -rules is called a \blacksquare -tree. A statement p is \blacksquare -valid if there is a closed \blacksquare -tree with initial statement $\neg p$ ².

² In general, if \mathbf{R} is a collection of tree rules, a \mathbf{R} -tree is a tree constructed in accordance with the rules of \mathbf{R} , and a statement p is \mathbf{R} -valid if there is a closed \mathbf{R} -tree with initial statement $\neg p$. This should be borne in mind in connection with the logical systems to be presented in the sequel.

Let us use these new tree rules to establish some simple properties of the system. First, we show that the statement

$$\Box(p \rightarrow q) \rightarrow (\Box p \rightarrow \Box q)$$

is \blacksquare -valid.

$$\begin{array}{c}
 \neg[\Box(p \rightarrow q) \rightarrow (\Box p \rightarrow \Box q)] \\
 | \\
 \Box(p \rightarrow q) \quad (\#) \\
 \neg(\Box p \rightarrow \Box q) \\
 | \\
 \Box p \quad (*) \\
 \neg\Box q \\
 | \\
 \Diamond\neg q \quad (+) \\
 \hline
 \neg q \quad (++) \\
 | \\
 p \quad (**) \\
 | \\
 p \rightarrow q \quad (##) \\
 \swarrow \quad \searrow \\
 \neg p \quad \quad q \\
 \times \quad \quad \times
 \end{array}$$

Here (++) is derived from (+) by the \Diamond -rule, and (**) from (*), as well as (##) from (#) by the \Box -rule.

Next, we show that, *if p is \blacksquare -valid, then so is $\Box p$, and conversely*. For the \blacksquare -validity of p means that there is a closed \blacksquare -tree with initial statement $\neg p$:

$$\begin{array}{c}
 (*) \\
 \neg p \\
 \vdots \\
 \times
 \end{array}$$

This yields a closed tree

$$\begin{array}{c}
 \neg \Box p \\
 | \\
 \Diamond \neg p \\
 \hline
 \neg p \\
 : \quad (*) \\
 \times
 \end{array}$$

Here the nodes below the horizontal line reproduce the tree (*). So p is valid.

Conversely, suppose that $\Box p$ is \blacksquare -valid. Then there is a closed \blacksquare -tree

$$(**) \quad \begin{array}{c}
 \neg \Box p \\
 : \\
 : \\
 \times
 \end{array}$$

Now the only \blacksquare -rule applicable to $\neg \Box p$ is the appropriate interchange rule, so that the tree (**) must begin:

$$\begin{array}{c}
 \neg \Box p \\
 | \\
 \Diamond \neg p \\
 :
 \end{array}$$

Similarly, the only rule applicable to $\Diamond \neg p$ is the \Diamond -rule, so (**) must look like

$$\begin{array}{c}
 \neg \Box p \\
 | \\
 \hline
 \Diamond \neg p \\
 \neg p \\
 : \\
 : \\
 \times
 \end{array}$$

But then the portion of this tree below the horizontal line is a closed tree with initial statement $\neg p$. Accordingly p is valid.

Exercises. 1. By constructing closed trees, establish the \blacksquare -validity of the statements $\Box(p \wedge q) \leftrightarrow \Box p \wedge \Box q$, $\Diamond(p \vee q) \leftrightarrow (\Diamond p \vee \Diamond q)$, $\Box p \vee \Box q \rightarrow \Box(p \vee q)$, $(\Box p \rightarrow \Diamond q) \rightarrow \Diamond(p \rightarrow q)$, $\Diamond p \wedge \Box q \rightarrow \Diamond(p \wedge q)$, and $(\Box p \rightarrow \Diamond q) \rightarrow \neg \Box \mathbf{f}$ (here \mathbf{f} is any contradiction, e.g. $A \wedge \neg A$).

2. Show that, \blacksquare satisfies the *disjunction principle*: if $\Box p \vee \Box q$ is \blacksquare -valid, then at least one of p , q is \blacksquare -valid. (Hint: consider a closed tree with initial statement $\neg(\Box p \vee \Box q)$ and apply the same sort of analysis as was applied to the tree (**) above.)

INTERPRETATIONS OF CONTEXTUAL STATEMENTS

As one might expect, the formal definition of an *interpretation* of contextual statements involves both the abstract notion of a *context* and the relation of *relevance* among concepts. Thus we define a *contextual structure* to be an ordered pair $(C, R) = \mathbf{C}$ in which C is a nonempty set and R is a binary relation on C . The members of C are called *contexts* of \mathbf{C} and R the *relevance relation* of \mathbf{C} . We use symbols a, b, c to indicate members of C ; aRb , also written $b\Re a$, is read " b is relevant to a ."

An *interpretation* of contextual statements in a contextual structure \mathbf{C} is a function \mathbf{I} which, to each pair (p, a) consisting of a contextual statement p and a context a , assigns an element $\mathbf{I}(p, a)$ of the set of truth values $\{t, f\}$ in such a way that

- | | | | |
|-----|--|-------------------|--|
| (1) | $\mathbf{I}(\neg p, a) = t$ | \Leftrightarrow | $\mathbf{I}(p, a) = f$ |
| (2) | $\mathbf{I}(p \wedge q, a) = t$ | \Leftrightarrow | $\mathbf{I}(p, a) = \mathbf{I}(q, a) = t$ |
| (3) | $\mathbf{I}(p \vee q, a) = t$ | \Leftrightarrow | $\mathbf{I}(p, a) = t$ or $\mathbf{I}(q, a) = t$ |
| (4) | $\mathbf{I}(p \rightarrow q, a) = t$ | \Leftrightarrow | $\mathbf{I}(p, a) = f$ or $\mathbf{I}(q, a) = t$ |
| (5) | $\mathbf{I}(p \leftrightarrow q, a) = t$ | \Leftrightarrow | $\mathbf{I}(p, a) = \mathbf{I}(q, a)$ |
| (6) | $\mathbf{I}(\Box p, a) = t$ | \Leftrightarrow | $\mathbf{I}(p, b) = t$ for every b in C such that aRb |
| (7) | $\mathbf{I}(\Diamond p, a) = t$ | \Leftrightarrow | $\mathbf{I}(p, b) = t$ for some b in C such that aRb . |

We think of $\mathbf{I}(p, a) = t$ as asserting that

p holds (under \mathbf{I}) in the context a.

Thus clause **(6)** may be construed as saying that

$\Box p$ holds in a context just when *p holds in all contexts relevant to the given one,*

and clause **(7)** reads

$\Diamond p$ holds in a context just when *p holds in at least one context relevant to the given one*

It follows immediately that, if *a* is a context with *no* contexts relevant to it, then, for any statement *p*, $\Box p$ holds in *a* and $\Diamond p$ fails to hold in *a*.

It will be convenient to write

$$a \Vdash_{\mathbf{I}} p \text{ or } a \Vdash p$$

for $\mathbf{I}(p, a) = t$. The assertion $a \Vdash p$ is read “*a forces (the truth of) p*”. We also write

$$a \nVdash p$$

for the negation of $a \Vdash p$.

Exercise. Show that $a \Vdash \Diamond p$ if and only if $a \Vdash \neg \Box \neg p$.

Clearly any assignment of truth values to pairs (A, a) , where *A* is a statement letter and *a* a context of \mathbf{C} generates a unique interpretation determined by clauses (1) - (7). So in specifying an interpretation in a given contextual structure we need only specify the truth values it assigns to pairs of that form.

We say that a contextual statement *p* is *true* under an interpretation \mathbf{I} in a contextual structure $\mathbf{C} = (C, R)$ if $a \Vdash_{\mathbf{I}} p$ for all *a* in *C*, that is, if *p* holds under

I in every context of \mathbf{C} . We say that p is *satisfiable* if $a \Vdash_I p$ for some interpretation I and some context a .

We now show that **■-valid contextual statements are true under every interpretation.** (Recall that "■-valid" means "negation generating a closed ■-tree.") This is proved in the same way as the inference correctness for propositional trees. We first specify what it means for a tree rule to be *correct*. If the rule is an old (noncontextual) rule or either of the interchange rules, we say that it is correct if whenever its premise holds under a given interpretation in a given context, all the statements in at least one of its lists of conclusions hold under that interpretation. As for the \Box - and \Diamond -rules, we say that either is correct if whenever its premise is true in a given context under a given interpretation, its conclusion holds under the same interpretation *in some context relevant to the given one*. It is readily shown that all tree rules are correct in this sense. Thus, starting with a satisfiable statement q , there is an interpretation under which, and a context in which, q is true. Since each tree rule is correct, it readily follows that any tree with initial statement q will contain at least one complete open path. If p is valid, then the finished tree with initial statement $\neg p$ is closed, and so $\neg p$ cannot be satisfiable; in other words p is true under every interpretation.

As in the case of ordinary propositional logic, the tree method for contextual logic can be used to generate *counterexamples* or *countermodels*, that is, interpretations in which invalid statements are *false*. We give a couple of examples which will serve to indicate the general procedure.

1. A countermodel for $\Box A \rightarrow \Box \Box A$. Here we generate the following finished ■-tree:

$$\begin{array}{c}
 \neg(\Box A \rightarrow \Box \Box A) \\
 | \\
 \Box A \\
 \neg \Box \Box A \quad 1 \\
 | \\
 \Diamond \neg \Box A \\
 \hline
 \end{array}$$

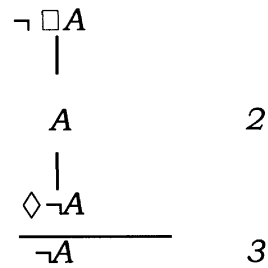

Since this tree contains *two* horizontal lines, it contains *three* contexts which we label 1, 2, 3, and each context is relevant to the one immediately below it. This may be represented by a "relevance diagram"

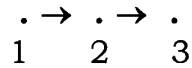

in which the nodes represent contexts and each arrow goes from a context to one relevant to it. The diagram determines a contextual structure $\mathbf{C} = (C, R)$ in which $C = \{1, 2, 3\}$ and $R = \{(1, 2), (2, 3)\}$. The countermodel will be an interpretation \mathbf{I} in \mathbf{C} making the initial statement of the tree false in the context (1) in which it appears. As with propositional trees we allow the truth values assigned to statement letters to be determined by whether they occur positively or negatively, only now this assignment will also depend on the *context* in which they occur. We see that, in the tree above, A occurs positively in context 2 and negatively in context 3. So our interpretation \mathbf{I} we should define $\mathbf{I}(A, 2) = t$, $\mathbf{I}(A, 3) = f$. (The value of $\mathbf{I}(A, 1)$ is irrelevant.) Our interpretation may then be displayed by the diagram

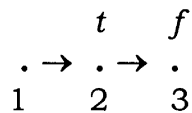

Let us verify that $\Box A \rightarrow \Box \Box A$ is false under \mathbf{I} in context 1. Since 2 is the only context relevant to 1, and $2 \Vdash A$, it follows that $1 \Vdash \Box A$. On the other hand, since 3 is the only context relevant to 2, and $3 \not\Vdash A$, it follows that $2 \not\Vdash \Box A$. But this means that $1 \not\Vdash \Box \Box A$. Therefore $1 \not\Vdash \Box A \rightarrow \Box \Box A$, as claimed. So \mathbf{I} is a countermodel for $\Box A \rightarrow \Box \Box A$.

2. A countermodel for $\Box(A \vee B) \rightarrow \Box A \vee \Box B$. In this case we generate the following finished tree:

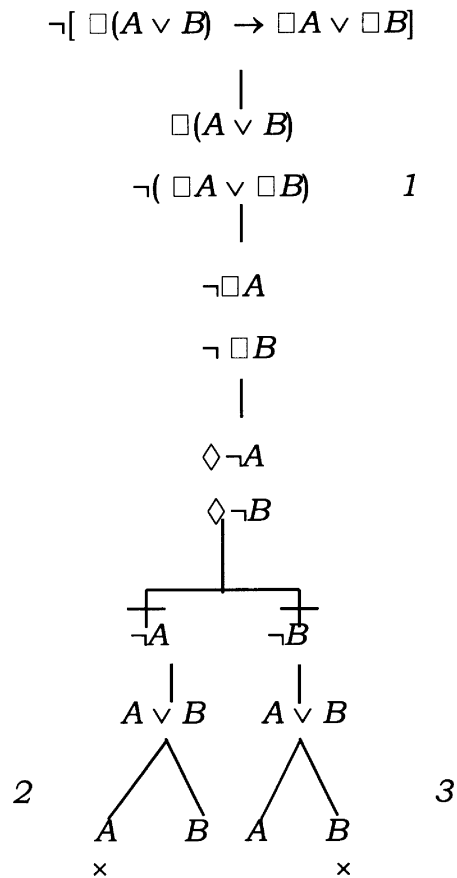

In this case the diagram of the interpretation \mathbf{I} determined by the tree is, writing t, f and \mathbf{t}, \mathbf{f} for the truth values assigned to A, B respectively,

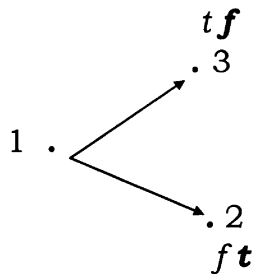

Let us verify that $\Box(A \vee B) \rightarrow \Box A \vee \Box B$ is false under \mathbf{I} in context 1. To begin with, since $\mathbf{I}(A \vee B, 2) = \mathbf{I}(A \vee B, 3) = t$, and 2,3 are the only contexts relevant to 1, it follows that $1 \Vdash \Box(A \vee B)$. On the other hand, since $\mathbf{I}(A, 2) = \mathbf{I}(B, 3) = f$, it follows that $\mathbf{I}(\Box A, 1) = \mathbf{I}(\Box B, 1) = f$. Therefore $1 \not\Vdash \Box A \vee \Box B$, and so $1 \not\Vdash \Box(A \vee B) \rightarrow (\Box A \vee \Box B)$ as claimed.

Exercise. In a way similar to the two examples above, construct countermodels to the following statements: **(i)** $\Box A \rightarrow A$, **(ii)** $A \rightarrow \Box A$, **(iii)** $\Box A \rightarrow \Diamond A$, **(iv)** $\Diamond \Box A \rightarrow A$, **(v)** $\Box(\Box A \rightarrow A) \rightarrow \Box A$. Show that $\Box A \rightarrow \Box \Box A$ is true in context 1 of the countermodel for **(i)**.

Although we shall not prove it here, it can be shown that this method of construction works in general, that is, each \blacksquare -invalid contextual statement is false under some interpretation. Equivalently, any contextual statement true under every interpretation is valid.

OTHER SYSTEMS OF CONTEXTUAL LOGIC

So far we have imposed no conditions whatsoever on relevance relations. One possible and, indeed, natural condition to consider is that of *reflexivity*: aRa for any $a \in C$. This condition means that each context is *self-relevant*. A contextual structure whose relevance relation R satisfies this condition is called *reflexive*. Truth in reflexive contextual structures is captured by adding the following \Box -*elimination rule* to our system \blacksquare of tree rules:

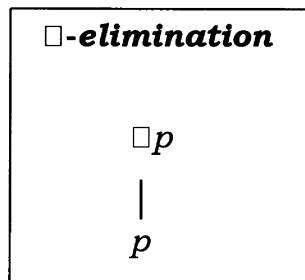

We write **■1** for the resulting system of tree rules.

Clearly $\Box A \rightarrow A$ becomes a **■1**-valid statement. On the other hand, the statement $\Box A \rightarrow \Box\Box A$ remains **■1**-invalid. This can be seen by returning to the tree on p. 43 which generates a countermodel for $\Box A \rightarrow \Box\Box A$. This tree can be finished in accordance with the rules of **■1** by adding a node with "A" on it in context 1. Since we want the relevance relation of our interpretation to be *reflexive*, the original relevance diagram must now have *loops* attached to each node, as in

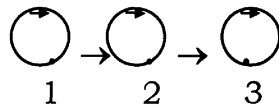

And in addition to assigning the value "t" to A in context 2, and "f" in context 3, the interpretation must assign "t" to A in context 1. Then, as before, $\Box A \rightarrow \Box\Box A$ is false in context 1 under this interpretation.

Exercises. 1. Show that $p \rightarrow \Diamond p$ is **■1**-valid, and construct countermodels to show that the statements $\Diamond\Box A \rightarrow A$ and $\Box(\Box A \rightarrow A) \rightarrow \Box A$ are both **■1**-invalid.

2. Show that **■1** satisfies the disjunction principle: for any statements p, q , if $\Box p \vee \Box q$ is **■1**-valid, then at least one of p, q is **■1**-valid.

Another natural condition that can be imposed on a relevance relation is that it be *transitive*: $(aRb \wedge bRc) \Rightarrow aRc$. A contextual structure whose relevance relation satisfies this condition is called *transitive*. Truth in transitive contextual structures is captured by adding to the following rule to the system **■**:

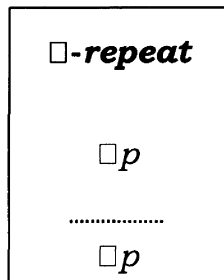

(Recall that the broken line indicates that if a new context is introduced, something may be asserted in it.) The resulting system is denoted by **■2**.

The closed tree below shows that $\Box p \rightarrow \Box\Box p$ is **■2**-valid.

$$\begin{array}{c}
 \neg(\Box p \rightarrow \Box\Box p) \\
 \quad | \\
 \quad \Box p \\
 \quad \quad | \\
 \quad \quad \neg \Box\Box p \\
 \quad \quad \quad | \\
 \quad \quad \quad \Diamond \neg \Box p \\
 \quad \quad \quad \hline
 \quad \quad \quad \neg \Box p \\
 \quad \quad \quad | \\
 \quad \quad \quad \Box p \\
 \quad \quad \quad \times
 \end{array}$$

Here the last line is derived from the second by the \Box -repeat rule.

Exercises. 1. Show that the statement $\Diamond\Diamond p \rightarrow \Diamond p$ is **■2**-valid.

2. Show that **■2** satisfies the disjunction principle: for any statements p, q , if $\Box p \vee \Box q$ is **■2**-valid, then at least one of p, q is **■2**-valid.

Invalidity in **■2** is established, as before, by using trees to generate countermodels, only now the contextual structure in each countermodel must be *transitive*. For instance, it will be found that this is the case for the countermodels for $\Diamond A \rightarrow A$ and $\Diamond\Box A \rightarrow A$ in the exercise on p.42. So neither of these two statements are **■2**-valid.

The system **■3** is obtained by amalgamating **■1** and **■2**, in other words, by adding both the \Box -elimination and \Box -repeat rules to **■**. **■3** captures truth in *preordered* contextual structures, those whose relevance relations are *transitive* and *reflexive*, that is, *preorderings*.

Exercises. 1. Show that the following statements are **■3**-valid: **(i)** $\diamond\diamond p \leftrightarrow \diamond p$; **(ii)** $\Box\diamond\Box p \leftrightarrow \Box\diamond p$; **(iii)** $\diamond\Box\diamond\Box p \leftrightarrow \diamond\Box p$; **(iv)** $\Box\diamond(p \rightarrow \Box p)$; **(v)** $\Box\diamond(\diamond p \rightarrow p)$; **(vi)** $\Box\diamond(\Box\diamond p \rightarrow p)$.

2. Show that the statements $\diamond A \rightarrow A$, $\Box\diamond A \rightarrow A$ and $\diamond\Box A \rightarrow A$ are **■3**-invalid.

3. Show that **■3** satisfies the disjunction principle: for any statements p, q , if $\Box p \vee \Box q$ is **■3**-valid, then at least one of p, q is **■3**-valid.

Another possible condition on a relevance relation is the extreme (but not unnatural) one that *all contexts are relevant to one another*. A contextual structure (C, R) satisfying this condition will then have $R = C \times C$ —we shall call such contextual structures *full*—and the clause for the truth of p under an interpretation \mathbf{I} in such a structure becomes

$$\mathbf{I}(\Box p, a) = t \Leftrightarrow \mathbf{I}(p, b) = t \text{ for every } b \in C.$$

That is, $\Box p$ is true in a *particular* context if and only if p is true in *all* contexts.

Similarly, $\diamond p$ is true in a particular context if and only if p is true in *some* context. In this event, it is natural to say that the truth of $\Box p$ means the *necessary* truth of p —truth in *every* conceivable context—and the truth of $\diamond p$ means the *possible* truth—truth in *some* conceivable context. Construed in this way, \Box and \diamond are the so-called *modal operators* of *necessity* and *possibility*. For this reason, what we have called contextual logic is usually known as *modal logic*.

Let **■4** be the system obtained from **■1** by adding the additional “closure” rule:

(■4closure) *If either of the pairs of statements $(\Box p, \neg p)$, or $(\Box\neg p, p)$ occur in a path, close the path.*

■4 captures truth in full contextual structures.

As an illustration of how this new rule works, let us show that the statement $\diamond\Box p \rightarrow \Box p$ is **■4**-valid. Here is the relevant tree:

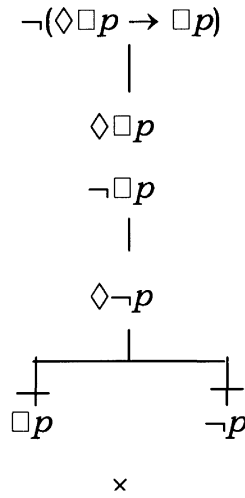

Here $\Box p$ and $\neg p$ appear on different tines of the fork, but nevertheless in the tree's single path, which therefore closes.

Exercises. 1. (i) Establish the **■4**-validity of the following statements: **(i)** $\Box p \rightarrow p$, **(ii)** $p \rightarrow \diamond p$, **(iii)** $\Box p \leftrightarrow \Box\Box p$, **(iv)** $\diamond\diamond p \leftrightarrow \diamond p$, **(v)** $\Box\diamond\Box p \leftrightarrow \Box\diamond p$, **(vi)** $\Box p \leftrightarrow \diamond\Box p$, **(vii)** $\diamond p \leftrightarrow \Box\diamond p$, **(viii)** $\diamond\Box p \rightarrow p$. Deduce that in **■4** any statement of the form $\Delta\Delta\Delta\Delta\dots p$, where each " Δ " is either \Box or \diamond , is either equivalent to $\diamond p$, or to $\Box p$. Deduce from **(vii)** that **■4** does not satisfy the disjunction principle.

2. By constructing countermodels, show that the statements $\Box\diamond A \rightarrow A$, $A \rightarrow \Box A$, $\diamond A \rightarrow A$ and $\Box(\Box A \rightarrow A) \rightarrow \Box A$ are **■4**-invalid. (Remember that a **■4** countermodel has to be a *full* contextual structure.)

3. (i) Show that the tree rules



are correct for interpretations in contextual structures in which the relevance relation is the *identity relation*, that is, in which each context is *relevant only to itself*.

(ii) Show that the "premiseless" tree rule

$$\frac{}{\Box p}$$

is correct for interpretations in contextual structures in which the relevance relation is *empty*, that is, in which *no contexts are relevant to one another*.

OTHER INTERPRETATIONS OF \Box AND \Diamond

We have seen that, in addition to its "contextual" interpretation, one possible meaning that can be assigned to \Box is "it is *necessarily true* that". This is known as the *alethic* interpretation (from Greek *aletheia*, "truth"). There are several others, for example: "it is *known* that", the *epistemic* interpretation (from Greek *episteme*, "knowledge"); "it is *believed* that", the *doxastic* interpretation (from Greek *doxa*, "opinion"); "it is *obligatory* that", the *deontic* interpretation (from Greek *deon*, "duty"); "it is *demonstrable* that", the *apodeictic* interpretation (from Greek *apodeiknunai*, "demonstrate").

As we have remarked, the system **■4** is a good set of rules for the alethic interpretation. The system **■3** provides a reasonably faithful set of rules for the epistemic interpretation, and **■2** for the doxastic interpretation. As for the deontic interpretation, the only rule which would seem to be correct (in addition to those of the basic system **■**) is

$$\frac{\Box p}{\Diamond p}$$

"whatever is obligatory is permissible." The system obtained by adding this rule to **■** is denoted by **■½**.

Exercises. 1. Show that the above rule for the deontic interpretation is equivalent to the following "closure" rule:

$\Box p$

:

:

 $\Box \neg p$

×

2. Why isn't \blacksquare_1 suitable for the doxastic interpretation? What about $\blacksquare_{1/2}$?

Chapter VI
Intuitionistic Logic

VI. Intuitionistic Logic

The idea behind *intuitionistic logic* is that statements are only asserted to be true or false when one is in possession of, or can in principle produce, *evidence* for the fact. Evidence might take the form of a proof, or even a direct verification. It is reasonable to express the fact that such evidence can be produced by saying that the statement in question is *known* to be true—or false—as the case may be.

In this event, certain classically valid principles will no longer remain valid. For example, to assert the truth of the statement $p \vee \neg p$ is now to assert that

p is known to be true or known to be false,

which is clearly not the case in general. (To see this, take p to be the statement "Aldebaran has planets.") Similarly, to assert the truth of the statement $\neg \neg p \rightarrow p$ is to assert that

if "p is known to be false" is known to be false, then p is known to be true.

Again, by taking p to be the same statement as before, this can be seen not to be true in general. Thus, while

Aldebaran is known not to have planets is known to be false,

it is *not* the case that

Aldebaran has planets is known to be true.

The crucial feature of intuitionistic reasoning is that "not (known to be) true" is *not the same as* "(known to be) false".

We see, then, that intuitionistic logic (so defined) is a kind of *epistemic* (or *apodeictic*) logic. The principal difference between them is that, in epistemic logic, as in any contextual logic, statement operators \Box , \Diamond are introduced as explicit devices to represent knowledge or evidence, thereby enlarging the class of statements, while the meaning of—and thus the logical principles

governing—the statements on which they operate *remains the same*: simple truth or falsity. In intuitionistic logic, on the other hand, the criterion of evidence is, so to speak, *injected into the meaning of the statements themselves*. As we have seen above, this results in *a change in the rules of reasoning*.

Although in presenting intuitionistic logic we shall not introduce new propositional operators in the usual sense, the tree rules we shall formulate for it will involve a new piece of notation—the *interrogative sign* $?$ —which will allow us to express in a purely formal way the idea of a sentence—like the one above—which is *not known to be true*. Thus, for any statement p , we will be able to write $?p$ and think of it as asserting that p is *not known to be true*, or that *we do not possess evidence for p* . Clearly $?p$ does not entail $\neg p$, that is, it does not entail that p is known to be false. As we have said, we do *not* regard $?$ as a new logical operator, nor do we regard $?p$ as a new statement of our logical system. Rather, expressions of the form $?p$ are to be viewed as *purely formal constituents of trees*. The $?$ sign is only allowed to be placed *at the front* of any statement. Thus no brackets are needed for writing interrogatives: for example in $?p \wedge q$ the $?$ sign must apply to the *whole* statement $p \wedge q$, and not just to p .

As a kind of epistemic logic, intuitionistic logic is related to the system **■3** of contextual logic considered in the previous chapter. Recall that this latter captures truth in *preordered* contextual structures, that is, those in which the relevance relation is *reflexive* and *transitive*. These structures also furnish natural interpretations of statements of intuitionistic logic. When playing that role, *contexts* in such structures should be thought of *stages of knowledge*, and relevance relations R as relations of *possible development of knowledge*. That is, if a and b are stages of knowledge, aRb is understood to mean that what is known at stage b is a possible development of what is known at stage a . When R is thought of in this way, it is quite natural to require it to be both reflexive and transitive.

We now state our tree rules for intuitionistic propositional logic. They fall into the following three groups:

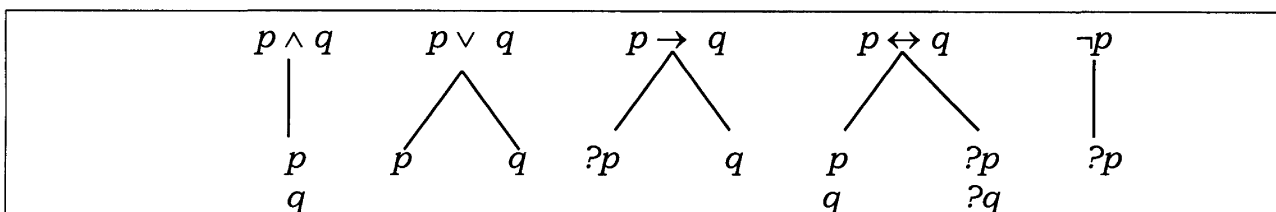

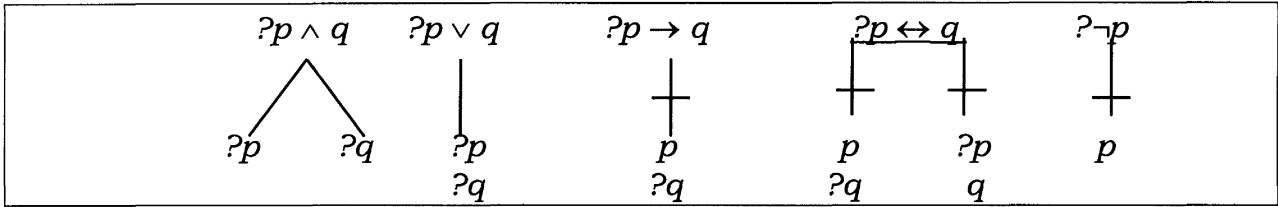

Transport rule. We are allowed to carry any statement *not marked by "?"* across any horizontal line introduced by the $? \rightarrow$, $? \leftrightarrow$, and $? \neg$ rules.

Closure rule. A path is *closed* when (and only when), both p and $?p$ occur on it *not separated by a horizontal line*. When this is the case, the path is marked, as before, by "x". (And, as usual, a tree is closed if all its paths are.)

Note that all these rules—apart from those for \neg , $? \rightarrow$, $? \leftrightarrow$, $? \neg$ and the transport rule—are essentially the corresponding classical rules with "?" in place of " \neg ". The \neg rule (which is obviously correct) is a device for converting $\neg p$ into an expression we can work with, since our rules are formulated in terms of "?" rather than " \neg ". Clearly the negation rule allows us to close a path if both p and $\neg p$ occur in it not separated by a horizontal line.

The \rightarrow rule deserves a detailed explanation. The key point is that—in contrast with classical logic—implication in intuitionistic logic is *not* material implication: that is, $p \rightarrow q$ is not equivalent to $\neg p \vee q$. In classical logic, the justification for identifying $p \vee q$ with $\neg p \vee q$ rests on the *principle of bivalence*, that either p or $\neg p$ must be true. Then, if p is true, so is q by the entailment of q by p . Hence $\neg p$ or q . Since intuitionistic logic does not (as we have seen) satisfy the principle of bivalence, this justification breaks down. What rule should we then adopt for implication? Let us look at things from an epistemic standpoint. Asserting that p *implies* q is known³ amounts to asserting that, if p comes to be known, then so thereby will q . Another way of putting this is to say that knowledge of $p \rightarrow q$ means possessing a method for converting knowledge of p into knowledge of q . In that case since in fact either p is known or p is not known, it follows that either p is not known or q is known. This the content of the \rightarrow rule. Similar remarks apply to the \leftrightarrow rule: note that, as for contextual trees, the fork indicates signifies the introduction of two new stages of knowledge *in a single path*.

³Henceforth the term "known", if used without further qualification, will mean "known to be true."

Next, consider the $?\rightarrow$ rule. Recall that in contextual logic the horizontal line indicated passage to a new context. Here the horizontal line may be taken to signalize *advancement to a later stage of knowledge*. Why is it needed? Because, if at some stage $p \rightarrow q$ isn't known, it *could* turn out that, at some later stage, p comes to be known without thereby causing q also to become known. This is the content of the $?\rightarrow$ rule. Similarly for the $? \leftrightarrow$ rule.

To justify the $? \neg$ rule, we observe that, if p isn't known to be false at a given stage, it could turn out that p becomes known at some later stage.

Two statements on the same path not separated by a horizontal line may be said to occur *at the same stage of knowledge*. The closure rule expresses the obvious fact that something can't be both known and not known at the same stage of knowledge.

The transport rule is designed to reflect a simple feature of our usual understanding of the claim that a statement is known to be true: if p is known at some stage, then it is true, and so will continue to be true—and known—at all later stages. This property is called *persistence*.

It is important to note that in applying the $? \rightarrow$ or $? \neg$ rules to statements on a single path *occurring at the same stage of knowledge*—that is, not separated by a horizontal line—it is necessary to introduce a separate and independent horizontal line for each such application. This is illustrated by

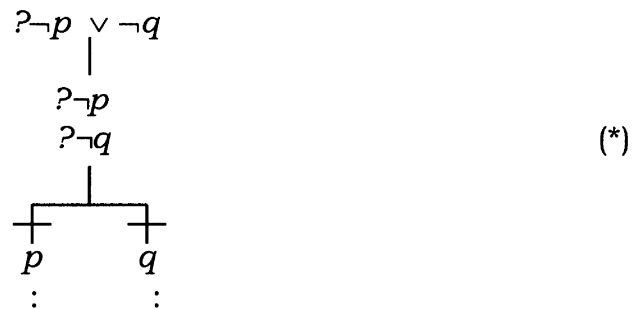

in which the fork is obtained by independent applications of the $? \neg$ rule to $? \neg p$ and $? \neg q$ *within a single path*.

The tree test for validity is applied to intuitionistic statements in just the same way as for classical statements, except that $?$ replaces \neg . That is, to determine whether a statement p is intuitionistically valid, start a tree with $?p$:

if the tree closes in the new sense, p is valid. If it doesn't, then p is invalid and a countermodel can be read off from the tree, as we shall see later.

Exercises. 1. Call a statement p *intuitionistically contradictory* if there is a closed intuitionistic tree with initial statement p . Show that p is intuitionistically contradictory if and only if $\neg p$ is intuitionistically valid.

2. Show that intuitionistic logic has the *weak disjunction property*: if $\neg p \vee \neg q$ is intuitionistically valid, then so is at least one of $\neg p$, $\neg q$. (Hint: consider the tree (*) on the previous page. Later we shall show that intuitionistic logic has the full disjunction property.)

3. Observe that replacing “?” by “ \neg ” and erasing the horizontal lines in each intuitionistic tree rule transforms it into the corresponding classical tree rule. Deduce that any intuitionistically valid statement is classically valid.

Here are some examples of intuitionistically valid statements. In each case, the tree closes through straightforward application of the above rules.

1. $p \rightarrow (q \rightarrow p)$.

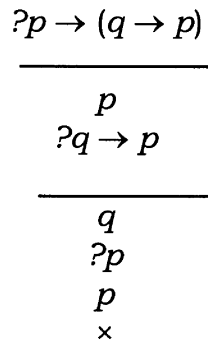

2. $p \rightarrow (q \rightarrow (p \wedge q))$.

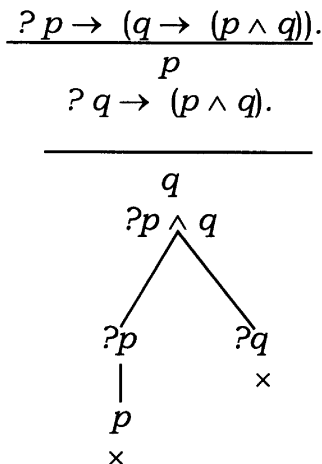

3. $(\neg p \vee q) \rightarrow (p \rightarrow q)$.

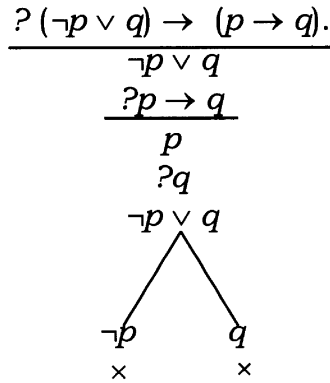

Exercise. By constructing closed trees, show that each of the following statements is intuitionistically valid. **(i)** $(p \rightarrow (q \rightarrow r)) \rightarrow ((p \rightarrow q) \rightarrow (p \rightarrow r))$. **(ii)** $(p \wedge q) \rightarrow p$. **(iii)** $p \rightarrow (p \vee q)$. **(iv)** $(p \rightarrow r) \rightarrow ((q \rightarrow r) \rightarrow (p \vee q \rightarrow r))$. **(v)** $(p \rightarrow q) \rightarrow ((p \rightarrow \neg q) \rightarrow \neg p)$. **(vi)** $\neg p \rightarrow (p \rightarrow q)$. **(vii)** $(p \wedge (p \rightarrow q)) \rightarrow q$. **(viii)** $[(p \vee \neg p) \rightarrow ((p \rightarrow q) \rightarrow (\neg p \vee q))]$. **(ix)** $p \rightarrow \neg\neg p$. **(x)** $\neg\neg p \leftrightarrow \neg p$. **(xi)** $(p \vee \neg p) \rightarrow (\neg\neg p \rightarrow p)$. **(xii)** $p \wedge (q \vee r) \leftrightarrow (p \wedge q) \vee (p \wedge r)$. **(xiii)** $p \vee (q \wedge r) \leftrightarrow (p \vee q) \wedge (p \vee r)$. **(xiv)** $\neg(p \vee q) \leftrightarrow \neg p \wedge \neg q$. **(xv)** $(\neg p \vee \neg q) \rightarrow \neg(p \wedge q)$. **(xvi)** $\neg p \leftrightarrow (p \rightarrow \mathbf{f})$, where \mathbf{f} is any contradiction. **(xvii)** $\neg\neg(p \wedge q) \leftrightarrow \neg\neg p \wedge \neg\neg q$. **(xviii)** $\neg\neg(p \vee \neg p)$. **(xix)** $\neg\neg(\neg\neg p \rightarrow p)$. **xx** $\neg\neg(p \rightarrow q \vee q \rightarrow p)$.

We now give a precise definition of the idea of an *interpretation* of statements of intuitionistic logic, similar to that given for contextual statements. For simplicity let us call a preordered contextual structure a *frame*. If $\mathbf{C} = (C, R)$ is a frame, the elements of C will be called *stages of knowledge*. Instead of aRb , we will write $a \leq b$ (or $b \geq a$) and read this " b is later than (or the same as) a ." or " a evolves into b ". An (intuitionistic) *interpretation* of statements in a frame \mathbf{C} is a function \mathbf{I} which assigns, to each pair (p, a) consisting of a sentence p and a stage of knowledge a , an element $\mathbf{I}(p, a)$ of $\{t, f\}$ in such a way that:

- | |
|--|
| <p>(i) For any statement letter A, if $\mathbf{I}(A, a) = t$ and $a \leq b$, then $\mathbf{I}(A, b) = t$.</p> <p>(ii) $\mathbf{I}(p \wedge q, a) = t \Leftrightarrow \mathbf{I}(p, a) = \mathbf{I}(q, a) = t$.</p> <p>(iii) $\mathbf{I}(p \vee q, a) = t \Leftrightarrow \mathbf{I}(p, a) = t$ or $\mathbf{I}(q, a) = t$.</p> <p>(iv) $\mathbf{I}(\neg p, a) = t \Leftrightarrow \mathbf{I}(p, b) = f$ for all $b \geq a$.</p> <p>(v) $\mathbf{I}(p \rightarrow q, a) = t \Leftrightarrow (\mathbf{I}(p, b) = t \Rightarrow \mathbf{I}(q, b) = t)$ for all $b \geq a$.</p> |
|--|

(vi) $I(p \leftrightarrow q, a) = t \Leftrightarrow I(p, b) = I(q, b)$ for all $b \geq a$.

Clearly any assignment of truth values satisfying condition **(i)** to all pairs (A, a) where A is a statement letter generates a unique interpretation determined by clauses **(ii)** - **(vi)**. So in specifying an interpretation in a given frame we need only specify the truth values it assigns to these pairs, at the same time ensuring that condition **(i)** is satisfied.

If $I(p, a) = t$, we say that p is *true* (under I) at *stage* a . Thus clause **(i)** stipulates that, if a statement letter is true at some stage, it remains true at all later stages: its truth is, in short, *persistent*. It can be shown that then the truth of any statement is persistent in this sense. Notice also that, according to clauses **(ii)** and **(iii)**, the truth of $p \wedge q$ and $p \vee q$ at a given stage is completely determined by the truth of p and the truth of q at *that stage*. However, this is not the case for $\neg p$, $p \rightarrow q$, or $p \leftrightarrow q$. For example, according to clause **(iv)**, $\neg p$ is true at a given stage if and only if p is false at *all later stages* (recall that "later" includes the given stage). And according to clause **(v)**, $p \rightarrow q$ is true at a given stage if and only if the truth of p implies that of q at *all later stages*.

If p is true under I at *every* stage, we shall say simply that p is *valid* under I .

In future we shall often write $a \Vdash_I p$ or $a \Vdash p$ for $I(p, a) = t$, and $a \nVdash p$ for $I(p, a) = f$. The *persistence property* for statements may then be expressed as:

if $a \Vdash_I p$ and $a \leq b$, then $b \Vdash_I p$.

Exercise. Prove that $a \Vdash \neg\neg p \Leftrightarrow$ for all $b \geq a$ there is $c \geq b$ such that $c \Vdash p$.

It can be shown without much difficulty that that the rules we have given are correct (in the usual sense) for intuitionistic statements provided we take the truth of $?p$ at any stage as meaning the falsity of p at *that stage*, with no reference to future stages—that is, $a \Vdash ?p$ is taken to mean $a \nVdash p$. Accordingly, in using the tree method in the familiar way (that is, as for statements of contextual logic) to generate countermodels for intuitionistically invalid statements, statement letters will be assigned the value f at stages where they occur preceded by $?$. This will result in the truth values of sentences changing from f to t as knowledge "advances". While perhaps a trifle counterintuitive, it is the price that must be paid for employing just the two truth values t and f in

intuitionistic interpretations. It is, nevertheless, perfectly consistent, since, while *truth* is required to persist, the same is not demanded of falsity.

By way of illustration, we now construct a countermodel for $(A \rightarrow B) \rightarrow (\neg A \vee B)$.

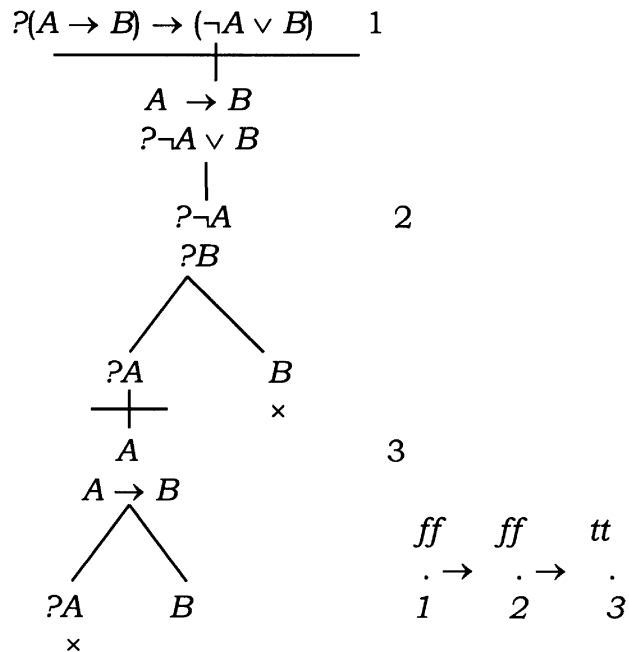

The tree is finished and has one open branch. That branch contains three stages of knowledge which we label 1, 2, 3. At stage 2, both $?A$ and $?B$ appear, so our interpretation will assign f to A and B there. Similarly, at stage 3, it assigns t to both A and B . Thus the countermodel \mathbf{I} will be an interpretation in the frame (C, R) where $C = \{1, 2, 3\}$, R is the usual "equal to or less than" relation on $\{1, 2, 3\}$, and $\mathbf{I}(A, 2) = \mathbf{I}(B, 2) = f$, $\mathbf{I}(A, 3) = \mathbf{I}(B, 3) = t$. (To respect persistence we must also take $\mathbf{I}(A, 1) = \mathbf{I}(B, 1) = f$, but this fact will not figure in our calculations.) Clearly $2 \Vdash A \rightarrow B$. On the other hand, since $3 \Vdash A$, we have $2 \not\Vdash \neg A$, so that $2 \not\Vdash \neg A \vee B$. Therefore $2 \not\Vdash (A \rightarrow B) \rightarrow (\neg A \vee B)$, so \mathbf{I} is a countermodel for $(A \rightarrow B) \rightarrow (\neg A \vee B)$.

Exercise. Using the tree method as above, construct intuitionistic countermodels for the following statements. **(i)** $\neg\neg A \rightarrow A$. **(ii)** $A \vee \neg A$. **(iii)** $(A \rightarrow B) \vee (B \rightarrow A)$. **(iv)** $(\neg A \rightarrow \neg B) \vee (\neg B \rightarrow \neg A)$. **(v)** $\neg A \vee \neg\neg A$. **(vi)** $\neg(A \wedge B) \rightarrow (\neg A \vee \neg B)$.

CORRECTNESS OF THE INTUITIONISTIC TREE RULES

We now take up once again the question of the correctness of the intuitionistic tree rules. First, what is actually meant by correctness? We say that a tree rule is *correct* if either

- (i) it is a rule that introduces no horizontal lines and whenever its premise holds at a given stage under a given interpretation, at least one of its lists of conclusions holds at that stage under that interpretation; or
- (ii) it is a rule that introduces new horizontal lines and whenever its premise holds at a given stage under a given interpretation, at least one of its lists of conclusions holds under the same interpretation at a stage later than (or the same as) the given one.

Correctness of all rules not introducing new horizontal lines is then clear. The correctness of (most of) the remaining rules may be indicated as follows.

$?p \rightarrow q$ if $a \not\Vdash p \rightarrow q$, then there is $b \geq a$ s.t. $b \Vdash p$ and $b \not\Vdash q$

$$\frac{\quad}{\begin{array}{l} p \\ ?q \end{array}}$$

$? \neg p$ if $a \not\Vdash \neg p$, then there is $b \geq a$ s.t. not $b \not\Vdash p$, i.e. $b \Vdash p$

$$\frac{\quad}{p}$$

Now suppose we start a tree T with a satisfiable statement q , i.e., one for which there is an interpretation \mathbf{I} and some stage at which it is true. Then each application of a tree rule will yield a stage at which at least one of its lists of conclusions is true under \mathbf{I} , so that T will always contain an open path.

If p is (tree) valid, then the finished tree starting with $?p$ is closed, so that, by the above, $?p$ cannot be satisfiable, in other words, p is valid under every interpretation.

Conversely, if the finished tree starting with $?p$ contains an open path, this will generate an interpretation in which p is false at its first stage, as presented in the example above.

STRENGTHENING THE INTUITIONISTIC TREE RULES

How might the intuitionistic tree rules be strengthened so as to obtain classical logic? The simplest way would be to erase the horizontal line in the $?\neg$ rule. In that case, both $\neg\neg p \rightarrow p$ and $p \vee \neg p$ become valid:

$$\begin{array}{c}
 ?\neg\neg p \rightarrow p \\
 \hline
 \neg\neg p \\
 ?p \\
 ?\neg p \\
 \hline
 p \\
 \times
 \end{array}$$

$$\begin{array}{c}
 ?p \vee \neg p \\
 | \\
 ?p \\
 ?\neg p \\
 \hline
 p \\
 \times
 \end{array}$$

Next, consider the classically valid statements $\neg A \vee \neg\neg A$, $(\neg A \rightarrow \neg B) \vee (\neg B \rightarrow \neg A)$. As we have seen, neither of these is intuitionistically valid. But each is valid in every *directed* frame, that is, one whose set of stages satisfies: for every a, b , there is c for which $c \geq a$ and $c \geq b$. To see this, we observe that, *in a directed frame, for any statement p , there can be no stages a, b for which $a \Vdash p$ and $b \Vdash \neg p$* . For if there were, there would also exist $c \geq a, b$, and then persistence would yield $c \Vdash p$ and $c \Vdash \neg p$, a contradiction. Now suppose given an interpretation in a directed frame, and suppose also that $a \not\Vdash \neg A \vee \neg\neg A$. Then $a \not\Vdash \neg A$ and $a \not\Vdash \neg\neg A$, so that there is $b \geq a$ for which $b \Vdash A$, and $c \geq a$ for which $c \Vdash \neg A$. This contradicts what we have just established concerning interpretations in directed frames. Therefore $a \Vdash \neg A \vee \neg\neg A$. Similarly, suppose if possible that $a \not\Vdash (\neg A \rightarrow \neg B) \vee (\neg B \rightarrow \neg A)$. Then $a \not\Vdash \neg A \rightarrow \neg B$ and $a \not\Vdash \neg B \rightarrow \neg A$. So there is $b \geq a$ such that $b \Vdash \neg A$ and $b \not\Vdash \neg B$, and $c \geq a$ for

which $c \models \neg B$ and $c \not\models \neg A$, whence $d \geq c$ for which $d \models A$. This again gives us a contradiction, and we conclude that $a \models (\neg A \rightarrow \neg B) \vee (\neg B \rightarrow \neg A)$.

Now consider the open finished trees

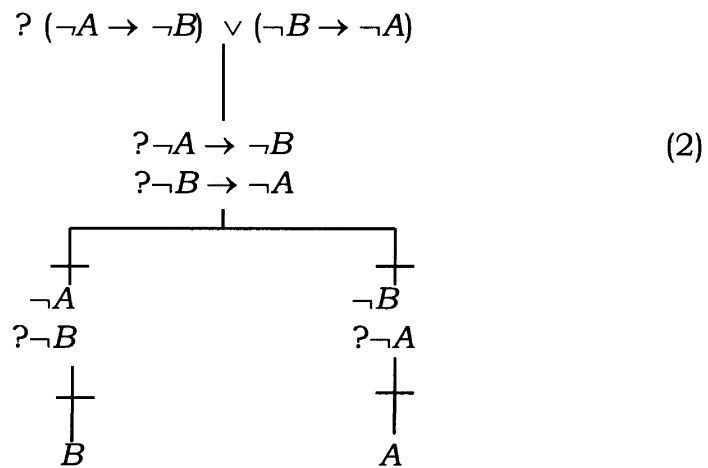
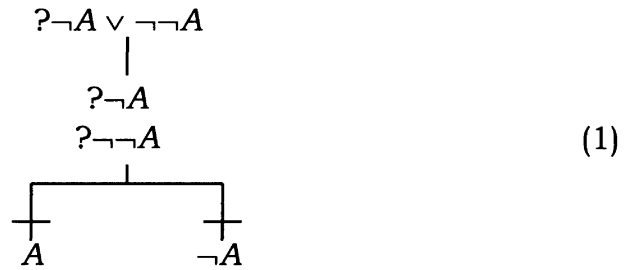

Both would close if each could be “fused” by appending, to (1):

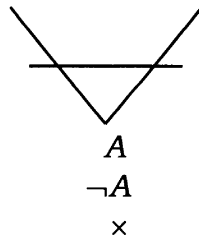

and to (2):

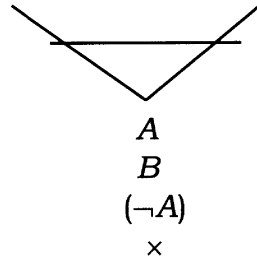

This leads us to formulate the

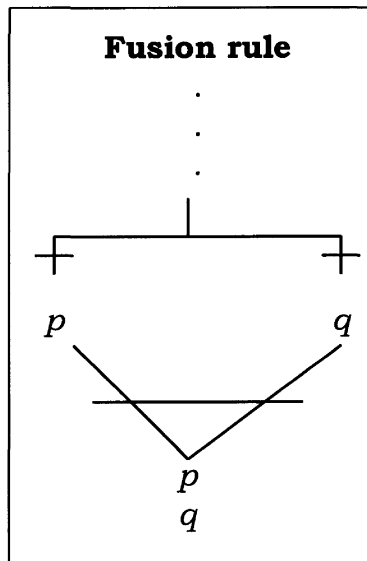

This rule is correct under interpretations in directed frames. For suppose $a \Vdash p$ and $b \Vdash q$ in such an interpretation. Then there are $a' \geq a$ and $b' \geq b$ for which $a' \Vdash p$ and $b' \Vdash q$. Taking $c \geq a', b'$, persistence gives $c \Vdash p$ and $c \Vdash q$.

Accordingly, to investigate validity in directed frames we should add the fusion rule. With this rule, as we have seen, both $\neg A \vee \neg\neg A$ and $(\neg A \rightarrow \neg B) \vee (\neg B \rightarrow \neg A)$ become valid. So also does $\neg(A \wedge B) \rightarrow \neg A \vee \neg B$:

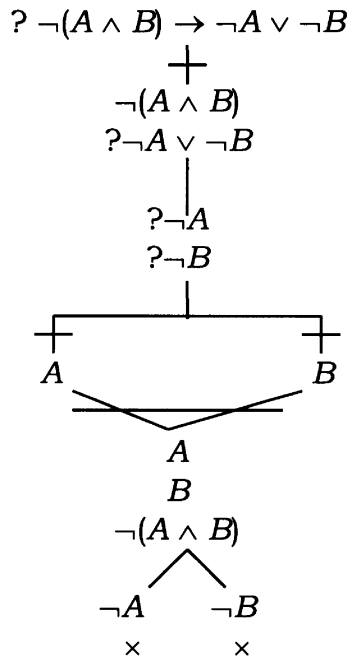

Next, consider the classically valid statement $(A \rightarrow B) \vee (B \rightarrow A)$. This statement is not intuitionistically valid, as is shown by the following tree:

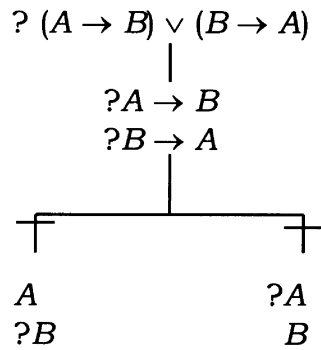

with associated countermodel

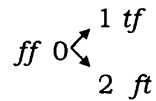

If we allow an application of the fusion rule the tree can be finished with

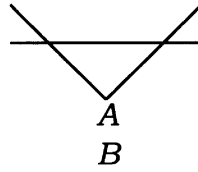

which leads to the *directed* countermodel

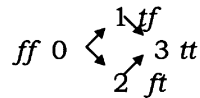

This shows that $(A \rightarrow B) \vee (B \rightarrow A)$ is invalid even in the presence of the fusion rule.

However, $(A \rightarrow B) \vee (B \rightarrow A)$ is valid under interpretations in *linearly ordered* frames. For suppose given an interpretation in a frame \mathbf{C} under which $(A \rightarrow B) \vee (B \rightarrow A)$ is false at some stage a . Then there must be stages $b, c \geq a$ for which $b \Vdash A, b \not\Vdash B, c \not\Vdash A, c \Vdash B$. If $b \leq c$, then $c \Vdash A$; if $c \leq b$, then $b \Vdash B$ —in both cases a contradiction. So $b \not\leq c$ and $c \not\leq b$, and \mathbf{C} is not linearly ordered.

Now consider the open tree

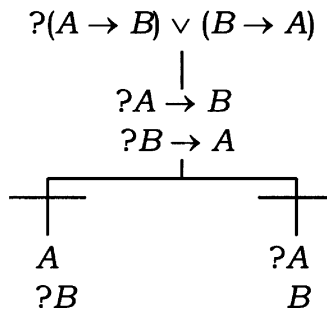

This would close if the bottom fork could be “linearized” to:

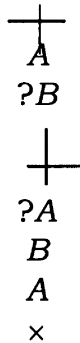

This suggests the

Linearization procedure: *in applying the $? \rightarrow$ or $? \neg$ rules to statements on a single path, extend the path without introducing forks (but retaining horizontal lines).*

This procedure can be shown to be correct (in an appropriate sense) under interpretations in linearly ordered frames. Linearization is thus a suitable procedure for investigating validity in linearly ordered frames.

With linearization $(A \rightarrow B) \vee (B \rightarrow A)$ becomes valid (as we have seen above), and so do $\neg A \vee \neg\neg A$ and $\neg(A \wedge B) \rightarrow \neg A \vee \neg B$:

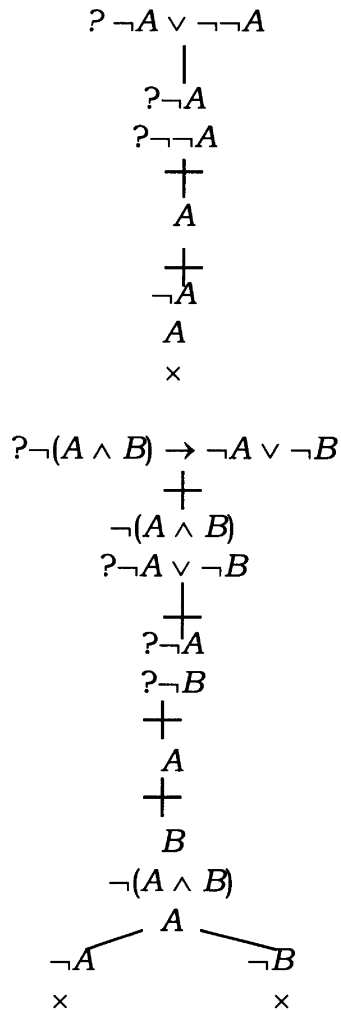

THE DISJUNCTION PROPERTY

The disjunction property. *If $p \vee q$ is (intuitionistically) valid, then either p is valid or q is valid.*

For suppose that neither p nor q is valid. Then there are interpretations \mathbf{I}, \mathbf{J} in frames \mathbf{C} and \mathbf{D} with bottom stages a_0, b_0 for which $a_0 \not\models p$ and $b_0 \not\models q$. Construct a new frame \mathbf{E} from \mathbf{C} and \mathbf{D} by pasting a new bottom stage u to the union of \mathbf{C} and \mathbf{D} :

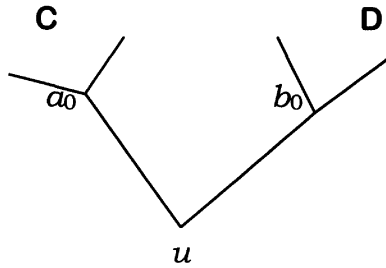

Define an interpretation \mathbf{K} in \mathbf{E} by stipulating that $\mathbf{K}(A, u) = f$ for all A and $\mathbf{K}(A, a) = \mathbf{I}(A, a)$ for any stage a of \mathbf{C} , $\mathbf{K}(A, b) = \mathbf{J}(A, b)$ for any stage b of \mathbf{D} . Since $a_0 \not\models p$ and $b_0 \not\models q$, it follows that $u \not\models p \vee q$, so that $p \vee q$ is not valid.

GLIVENKO'S THEOREM

Glivenko's theorem. *For any statement p , p is classically valid if and only if $\neg\neg p$ is intuitionistically valid.*

To prove this, we first observe that if a is a *maximal* stage in a frame—that is, if, for any stage b , $a \leq b \Rightarrow a = b$,—then $a \Vdash p$ for any classical tautology p .

We also note that, if p is intuitionistically invalid, then the tree method generates a finite frame in which p is false at its bottom stage. Therefore, if p is true in every finite frame, it is valid.

In a finite frame, for any stage a there is a maximal stage b for which $a \leq b$.

Now suppose that p is a classical tautology. Then, as observed, it is true at every maximal stage under any interpretation in any finite frame. In

particular, for any stage a in any such interpretation there is $b \geq a$ for which $b \Vdash p$. This implies that $a \Vdash \neg\neg p$ so $\neg\neg p$ is valid in every finite frame, and so valid.

A TRANSLATION OF INTUITIONISTIC LOGIC INTO ■3.

For each statement p define p^* by:

$$\begin{aligned} A^* &= \Box A \\ (p \wedge q)^* &= p^* \wedge q^* \\ (p \vee q)^* &= p^* \vee q^* \\ (\neg p)^* &= \Box \neg p^* \\ (p \rightarrow q)^* &= \Box (p^* \rightarrow q^*) \\ (p \leftrightarrow q)^* &= \Box (p^* \leftrightarrow q^*) \end{aligned}$$

It can be shown that, for any statement p , p is intuitionistically valid if and only if p^* is ■3-valid.

Consider, for example, $p \vee \neg p$.

$$(p \vee \neg p)^* = p^* \vee \Box \neg p^* = \Diamond p^* \rightarrow p^*,$$

which we have seen (exercise 2, p. 46) is ■3-invalid.

On the other hand, consider the statement $\neg\neg(p \vee \neg p)$. Here

$$(\neg\neg(p \vee \neg p))^* = \Box \neg \Box \neg (\Box p \vee \Box \neg p) \Leftrightarrow \Box \Diamond (\Diamond \Box p \rightarrow \Box p),$$

and this last statement is ■3-valid by exercise 1 (v), p. 46.

INTUITIONISTIC PREDICATE LOGIC

In intuitionistic predicate logic the following statements are valid:

$$\begin{array}{lll}
\exists x \neg p(x) \rightarrow \neg \forall x p(x) & \neg \exists x p(x) \rightarrow \forall x \neg p(x) & p \vee \forall x q(x) \rightarrow \forall x (p \vee q(x)) \\
\forall x (p(x) \rightarrow q) \leftrightarrow (\exists x p(x) \rightarrow q) & \exists x (p \rightarrow q(x)) \rightarrow (p \rightarrow \exists x q(x)) & \\
\exists x (p(x) \rightarrow q) \rightarrow (\forall x p(x) \rightarrow q) & \neg \neg \forall x (p(x) \leftrightarrow \forall x \neg \neg p(x)) &
\end{array}$$

But the following are not:

$$\begin{array}{lll}
\neg \forall x p(x) \rightarrow \exists x \neg p(x) & \forall x \neg \neg p(x) \rightarrow \neg \neg \forall x p(x) & \forall x (p \vee q(x)) \rightarrow p \vee \forall x q(x) \\
(p \rightarrow \exists x q(x)) \rightarrow \exists x (p \rightarrow q(x)) & (\forall x p(x) \rightarrow q) \rightarrow \exists x (p(x) \rightarrow q) & \\
\forall x \forall y (x = y \vee x \neq y) & \text{(nor even its } \neg \neg) &
\end{array}$$

Here are some concrete examples of intuitionistically invalid statements:

Let $A(n)$ be the assertion: “the n th place in the decimal expansion of π is a 7 and is preceded by six 7s”. Then for $\exists x A(x) \vee \neg \exists x A(x)$ to be intuitionistically valid we would require a proof yielding an n such that $A(n)$, or one showing that no such n exists. But we don’t have either. So $\exists x A(x) \vee \neg \exists x A(x)$ is not intuitionistically valid. On the other hand, $\neg \neg (\exists x A(x) \vee \neg \exists x A(x))$ is valid (since any statement of the form $\neg \neg (p \vee \neg p)$ is). Therefore the law of double negation fails for the statement $\exists x A(x) \vee \neg \exists x A(x)$. Finally, $\neg \neg (\exists x A(x) \vee \neg \exists x A(x))$ is intuitionistically equivalent to $\neg (\exists x A(x) \wedge \neg \exists x A(x))$ (which is obviously valid). But $\neg \exists x A(x) \vee \neg \neg \exists x A(x)$ is not assertable since we do not know either that it is impossible for there to exist a sequence of seven 7s in the decimal expansion of π nor whether it is impossible for there to exist no such sequence. This gives an instance of the intuitionistic failure of the law $\neg (p \wedge q) \rightarrow \neg p \vee \neg q$.

Chapter VII
Intuitionistic Contextual Logic

VII. Intuitionistic Contextual Logic

BASIC INTUITIONISTIC CONTEXTUAL LOGIC

In this final chapter we show how intuitionistic and contextual logic can be combined. This will be done, as before, by introducing the appropriate trees and rules governing their formation.

The notation for *intuitionistic contextual (IC) trees* is obtained by amalgamating that of intuitionistic trees with that of contextual trees with that, except that *the horizontal line of a contextual tree is now written as a double*

horizontal line, thus: ===== . So a single horizontal line still indicates a change of stage (of knowledge), but now a change of context is signaled by a double line. In that case an unqueried statement may always be carried across a single line, but not (in general) across a double line.

The system $\mathbf{I}\blacksquare$ of *basic intuitionistic contextual logic* consists of the intuitionistic tree rules together with the \blacksquare -rules (with double horizontal lines replacing single ones), and the *new rules*:

$$\boxed{\begin{array}{c} \text{?}\square\text{- rule} \\ \text{?}\square p \\ \hline \text{?}p \end{array}}$$

$$\boxed{\begin{array}{c} \text{?}\diamond\text{- rule} \\ \text{?}\diamond p \text{.....} \\ \hline \text{?}p \end{array}}$$

In the second of these rules the double broken line indicates that when some other rule allows us to introduce a new context (separated now by a double line) then the rule in question allows us to assert something there.

A path of an IC-tree is *closed* when both p and $?p$ occur in it not separated by a single or double horizontal line. A statement p is $\mathbf{I}\blacksquare$ -*valid* if there is a closed tree with initial statement $?p$ ⁴.

Here are some examples of $\mathbf{I}\blacksquare$ -valid statements.

⁴ In general, if \mathbf{R} is a collection of IC- tree rules, an \mathbf{R} -tree is an IC- tree constructed in accordance with the rules of \mathbf{R} , and a statement p is \mathbf{R} -*valid* if there is a closed \mathbf{R} -tree with initial statement $?p$. This should be borne in mind in connection with the logical systems to be presented in the sequel.

$$\boxed{\Box(p \rightarrow q) \rightarrow (\Box p \rightarrow \Box q)}$$

$$\begin{array}{c} ?\Box(p \rightarrow q) \rightarrow (\Box p \rightarrow \Box q) \\ \hline \Box(p \rightarrow q) \\ ?\Box p \rightarrow \Box q \\ \hline \Box p \\ ?\Box q \\ \hline \hline ?q \\ p \\ p \rightarrow q \\ \swarrow \searrow \\ ?p \quad q \\ \times \quad \times \end{array}$$

$$\boxed{\Diamond(p \vee q) \rightarrow \Diamond p \vee \Diamond q}$$

$$\begin{array}{c} ?\Diamond(p \vee q) \rightarrow \Diamond p \vee \Diamond q \\ \hline \Diamond(p \vee q) \\ ?\Diamond p \vee \Diamond q \\ | \\ ?\Diamond p \\ ?\Diamond q \\ \hline \hline p \vee q \\ ?p \\ ?q \\ \swarrow \searrow \\ p \quad q \\ \times \quad \times \end{array}$$

$$\boxed{\diamond p \wedge \Box q \rightarrow \diamond(p \wedge q)}$$

$$\underline{?\diamond p \wedge \Box q \rightarrow \diamond(p \wedge q)}$$

$$\diamond p \wedge \Box q$$

$$?\diamond(p \wedge q)$$

$$|$$

$$\diamond p$$

$$\Box q$$

$$p$$

$$q$$

$$?p \wedge q$$

$$?p$$

$$\times$$

$$?q$$

$$\times$$

$$\boxed{\diamond \neg p \rightarrow \neg \Box p}$$

$$\underline{?\diamond \neg p \rightarrow \neg \Box p}$$

$$\diamond \neg p$$

$$?\neg \Box p$$

$$\Box p$$

$$\neg p$$

$$p$$

$$\times$$

$$\boxed{\Box \neg p \rightarrow \neg \Diamond p}$$

$$\frac{\frac{\frac{? \Box \neg p \rightarrow \neg \Diamond p}{\Box \neg p}}{? \neg \Diamond p}}{\underline{\underline{\Diamond p}}}}{p}$$

$$\neg p$$

$$\times$$

OTHER SYSTEMS OF INTUITIONISTIC CONTEXTUAL LOGIC

Other systems of intuitionistic contextual logic are obtained by adding to **I■** certain of the contextual rules introduced in Chapter 5, and certain of the following new rules:

$$\boxed{\begin{array}{c} ?\Diamond\text{-elimination} \\ \\ ?\Diamond p \\ | \\ ?p \end{array}}$$

$$\boxed{\begin{array}{c} ?\Diamond\text{-repeat} \\ \\ ?\Diamond p \\ \dots\dots\dots \\ ?\Diamond p \end{array}}$$

(■-closure) *If the pair of statements $(\Box p, ?p)$, occur in a path, whether or not separated by horizontal lines, close the path.*

(◇-closure) *If the pair of statements $(?\Diamond p, p)$ occur in a path, whether or not separated by horizontal lines, close the path.*

We then obtain the following systems:

I■1	I■ + □-elimination + ?◇-elimination
I■2	I■ + □-repeat + ?◇-repeat
I■3	I■1 + I■2
I■4	I■1 + □-closure + ◇-closure

Here are some examples of valid statements in the various systems.

I■3- valid statements

$$\boxed{\Box p \rightarrow \Box \Box p}$$

$$\boxed{\Diamond \Diamond p \rightarrow \Diamond p}$$

$$\frac{? \Box p \rightarrow \Box \Box p}{\Box p}$$

$$\frac{\Box p}{? \Box \Box p}$$

$$\frac{? \Box \Box p}{? \Box p}$$

$$\frac{? \Box p}{\Box p}$$

×

$$\frac{? \Diamond \Diamond p \rightarrow \Diamond p}{\Diamond \Diamond p}$$

$$\frac{\Diamond \Diamond p}{? \Diamond p}$$

$$\frac{? \Diamond p}{\Diamond p}$$

$$\frac{\Diamond p}{? \Diamond p}$$

×

$$\boxed{\Box \Diamond \Box \Diamond p \rightarrow \Box \Diamond p}$$

$$\frac{? \Box \Diamond \Box \Diamond p \rightarrow \Box \Diamond p}{\Box \Diamond \Box \Diamond p}$$

$$\frac{\Box \Diamond \Box \Diamond p}{? \Box \Diamond p}$$

$$\frac{? \Box \Diamond p}{? \Diamond p}$$

$$\frac{? \Diamond p}{\Diamond \Box \Diamond p}$$

$$\frac{\Diamond \Box \Diamond p}{\Box \Diamond p}$$

$$\frac{\Box \Diamond p}{\Diamond p}$$

$$\frac{\Diamond p}{? \Diamond p}$$

×

$$\boxed{\Box\Diamond p \rightarrow \Box\Diamond\Box\Diamond p}$$

$$\frac{?\Box\Diamond p \rightarrow \Box\Diamond\Box\Diamond p}{\Box\Diamond p}$$

$$\frac{?\Box\Diamond\Box\Diamond p}{\Box\Diamond\Box\Diamond p}$$

$$\frac{?\Box\Diamond\Box\Diamond p}{\Box\Diamond\Box\Diamond p}$$

$$\frac{\Box\Diamond\Box\Diamond p}{\Box\Diamond p}$$

$$\frac{\Box\Diamond p}{\Box\Diamond p}$$

x

$$\boxed{\Diamond\Box\Box\Box p \rightarrow \Diamond\Box p}$$

$$\frac{?\Diamond\Box\Box\Box p \rightarrow \Diamond\Box p}{\Diamond\Box\Box\Box p}$$

$$\frac{?\Diamond\Box p}{\Box\Box\Box p}$$

$$\frac{\Box\Box\Box p}{\Diamond\Box p}$$

$$\frac{\Diamond\Box p}{?\Diamond\Box p}$$

x

$$\boxed{\Diamond\Box p \rightarrow \Diamond\Box\Box\Box p}$$

$$\frac{?\Diamond\Box p \rightarrow \Diamond\Box\Box\Box p}{\Diamond\Box p}$$

$$\frac{\Diamond\Box p}{\Diamond\Box p}$$

$$\frac{\Diamond\Box p}{\Diamond\Box\Box\Box p}$$

x

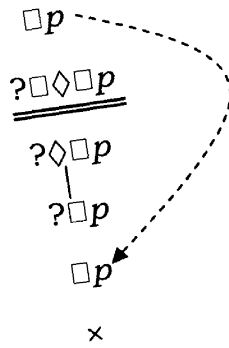

I 4-valid statements.

$$\Box p \rightarrow \Box\Box p$$

$$\begin{array}{c}
 \hline
 ?\Box p \rightarrow \Box\Box p \\
 \hline
 \Box p \\
 \hline
 ?\Box\Box p \\
 \hline
 ?\Box p \\
 \hline
 ?p \\
 \times
 \end{array}$$

$$\Diamond\Diamond p \rightarrow \Diamond p$$

$$\begin{array}{c}
 \hline
 ?\Diamond\Diamond p \rightarrow \Diamond p \\
 \hline
 \Diamond\Diamond p \\
 \hline
 ?\Diamond p \\
 \hline
 \Diamond p \\
 \hline
 ?p \\
 \hline
 p \\
 \times
 \end{array}$$

$$\neg\Diamond p \rightarrow \Box\neg p$$

$$\begin{array}{c}
 \hline
 ?\neg\Diamond p \rightarrow \Box\neg p \\
 \hline
 \neg\Diamond p \\
 ?\Box\neg p \\
 \hline
 ?\Diamond p \\
 \hline
 ?\neg p \\
 \hline
 p \\
 \times
 \end{array}$$

$$\boxed{\diamond \Box p \rightarrow \Box p}$$

$$\text{?} \diamond \Box p \rightarrow \Box p$$

$$\diamond \Box p$$

$$\text{?} \Box p$$

⊥		⊥
$\Box p$	x	$?p$

$$\boxed{\diamond p \rightarrow \Box \diamond p}$$

$$\text{?} \diamond p \rightarrow \Box \diamond p$$

$$\diamond p$$

$$\text{?} \Box \diamond p$$

⊥		⊥
p	x	$? \diamond p$

$$\boxed{\Box \diamond \Box p \rightarrow \Box \diamond p}$$

$$\text{?} \Box \diamond \Box p \rightarrow \Box \diamond p$$

$$\Box \diamond \Box p$$

$$\text{?} \Box \diamond p$$

$$\text{?} \diamond p$$

$$\diamond \Box \diamond p$$

$$\Box \diamond p$$

$$x$$

$$\boxed{\Box \diamond p \rightarrow \Box \diamond \Box \diamond p}$$

$$\text{?} \Box \diamond p \rightarrow \Box \diamond \Box \diamond p$$

$$\Box \diamond p$$

$$\text{?} \Box \diamond \Box \diamond p$$

$$\text{?} \diamond \Box \diamond p$$

$$\diamond p$$

$$?\Box\Diamond p$$

$$\frac{p}{\frac{?\Diamond p}{\Box\Diamond p}}$$

$$\times$$

$\Diamond\Box\Diamond\Box p \rightarrow \Diamond\Box p$

$$\frac{?\Diamond\Box\Diamond\Box p \rightarrow \Diamond\Box p}{\Diamond\Box\Diamond\Box p}$$

$$\Diamond\Box\Diamond\Box p$$

$$\frac{?\Diamond\Box p}{\Box\Diamond\Box p}$$

$$\Box\Diamond\Box p$$

$$?\Box p$$

$$?p$$

$$\frac{\Diamond\Box p}{\Box p}$$

$$\Box p$$

$$\times$$

$\Diamond\Box p \rightarrow \Diamond\Box\Diamond\Box p$

$$\frac{?\Diamond\Box p \rightarrow \Diamond\Box\Diamond\Box p}{\Diamond\Box p}$$

$$\Diamond\Box p$$

$$\frac{?\Diamond\Box\Diamond\Box p}{\Box p}$$

$$\Box p$$

$$\frac{?\Box\Diamond\Box p}{\Diamond\Box p}$$

$$\Diamond\Box p$$

$$\times$$

Exercise. Show that **I■**, **I■1**, **I■2**, and **I■3** all have the disjunction property: a disjunction $\Box p \vee \Box q$ is valid in any one of these systems iff at least one of p , q is also.

INTERPRETATIONS AND COUNTERMODELS

A *contextual frame* is a triple $\mathfrak{C} = (C, R, \leq)$ in which C is a nonempty set (the members of which will be called *stages*), R is a binary relation on C and \leq is a preordering on C satisfying:

1. $a \leq b \ \& \ bRc \Rightarrow aRc$.
2. $a \leq b \ \& \ aRc \Rightarrow \exists d(c \leq d \ \& \ bRd)$.

These conditions may be illustrated as follows:

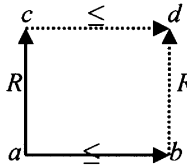
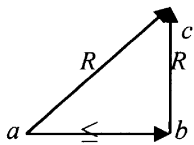

In words, condition 1 asserts:

if one stage evolves into a second, then any stage relevant to the latter is also relevant to the former.

and condition 2:

if, for two given stages, a , b there is a stage which evolves into a and to which b is relevant, then a can evolve into a stage which is itself relevant to b .

An interpretation \mathbf{I} of a propositional contextual vocabulary in a contextual frame \mathfrak{C} is a function \mathbf{I} which, to each pair (p, a) consisting of a contextual statement p and a context a , assigns an element $\mathbf{I}(p, a)$ of the set of truth values $\{t, f\}$ in such a way that

(i) For any statement letter A , if $\mathbf{I}(A, a) = t$ and $a \leq b$, then $\mathbf{I}(A, b) = t$.

- (ii) $I(p \wedge q, a) = t \Leftrightarrow I(p, a) = I(q, a) = t.$
 (iii) $I(p \vee q, a) = t \Leftrightarrow I(p, a) = t \text{ or } I(q, a) = t.$
 (iv) $I(\neg p, a) = t \Leftrightarrow I(p, b) = f \text{ for all } b \geq a.$
 (v) $I(p \rightarrow q, a) = t \Leftrightarrow (I(p, b) = t \Rightarrow I(q, b) = t) \text{ for all } b \geq a.$
 (vi) $I(p \leftrightarrow q, a) = t \Leftrightarrow I(p, b) = I(q, b) \text{ for all } b \geq a.$
 (vii) $I(\Box p, a) = t \Leftrightarrow I(p, b) = t \text{ for every } b \text{ in } C \text{ such that } aRb.$
 (viii) $I(\Diamond p, a) = t \Leftrightarrow I(p, b) = t \text{ for some } b \text{ in } C \text{ such that } aRb.$

If $I(p, a) = t$. at every stage a , we shall say simply that p is *valid* under I .

The forcing relation is defined as usual: $a \Vdash_I p$ means $I(p, a) = t$. Using conditions 1 and 2 above, the persistence property for \Vdash may be established:

$$a \Vdash p \text{ and } a \leq b \Rightarrow b \Vdash p.$$

Condition 1 yields the persistence of $\Box p$ and 2 that of $\Diamond p$.

It can be shown without much difficulty that the rules we have given are correct (in the usual sense) for intuitionistic contextual statements provided we take the truth of $?p$ at any stage as meaning the falsity of p at that stage, with no reference to future stages—that is, $a \Vdash ?p$ is taken to mean $a \not\Vdash p$. Accordingly, in using the tree method in the familiar way (that is, as for statements of contextual and intuitionistic logic) to generate countermodels for intuitionistic contextually invalid statements, statement letters will, as in the intuitionistic case, be assigned the value f at stages where they occur preceded by $?$.

Here are some countermodels for invalid statements in **I■3**.

$\neg \Diamond A \rightarrow \Box \neg A$ is **I■3**-invalid.

$$\begin{array}{c}
 \frac{? \neg \Diamond A \rightarrow \Box \neg A}{\neg \Diamond A} \\
 ? \Box \neg A \\
 \\
 ? \Diamond A \\
 \frac{? A}{? \neg A} \\
 \frac{? A}{A}
 \end{array}$$

This yields the **I■3**-interpretation:

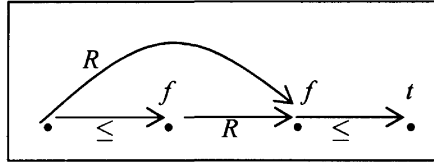

We verify that $1 \not\models \neg\Diamond A \rightarrow \Box\neg A$ in this interpretation. For this to be the case it suffices that (a) $2 \Vdash \neg\Diamond A$ and (b) $2 \not\models \Box\neg A$. Now (a) holds iff $2 \not\models \Diamond A$, which is the case since $2 \not\models A$ and $3 \not\models A$. As for (b), we observe that from $4 \Vdash A$ it follows that $3 \not\models \neg A$, and from this (b) follows immediately

$\neg\Box A \rightarrow \Diamond\neg A$ is **I■3**-invalid.

$$\begin{array}{c}
 \hline
 ?\neg\Box A \rightarrow \Diamond\neg A \\
 \hline
 \neg\Box A \\
 \\
 ?\Diamond\neg A \\
 ?\Box A \\
 \hline
 ?A \\
 ?\neg A \\
 \hline
 A
 \end{array}$$

This open tree yields the **I■3**-interpretation, in which we have assigned A the truth value t at stage 2:

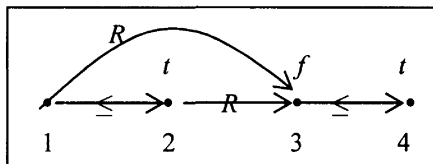

We verify that in this interpretation $1 \not\models \neg \Box A \rightarrow \Diamond \neg A$. For this to be the case it suffices that (a) $2 \Vdash \neg \Box A$ and (b) $2 \not\models \Diamond \neg A$. Now (a) holds iff $2 \not\models \Box A$ which latter is the case since $3 \not\models A$. And (b) holds iff $2 \not\models \neg A$ and $3 \not\models \neg A$; the former is the case since $2 \Vdash A$, and the latter since $4 \not\models A$.

$\Diamond A \wedge \Diamond B \rightarrow \Diamond(A \wedge B)$ is **I■3**-invalid

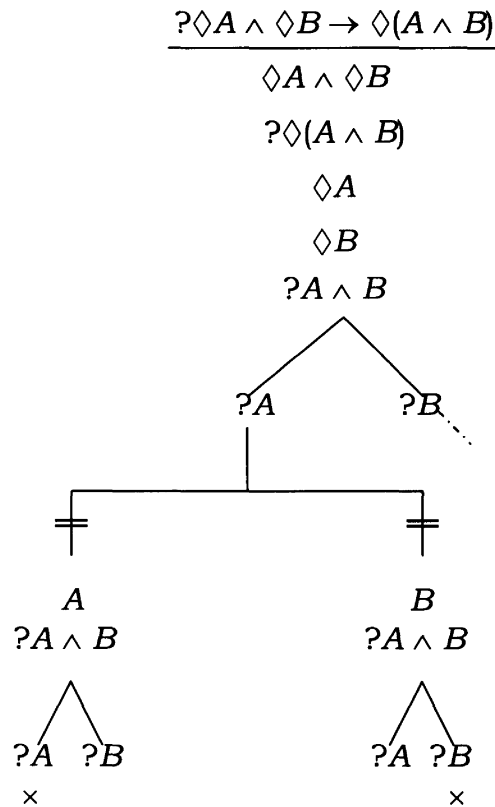

This open tree yields the **I■3**-interpretation

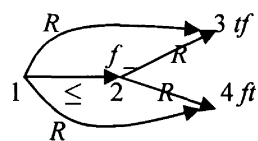

We verify that in this interpretation $1 \not\models \Diamond A \wedge \Diamond B \rightarrow \Diamond(A \wedge B)$. For this to be the case it suffices that (a) $1 \models \Diamond A \wedge \Diamond B$ and (b) $1 \not\models \Diamond(A \wedge B)$. Now (a) holds since $3 \models A$ and $4 \models B$; and (b) holds since $2 \not\models A$, $3 \not\models B$, and $4 \not\models B$.

Exercise. Show that $\neg \Box A \rightarrow \Diamond \neg A$ is **I■4**-invalid.

Solutions to Selected Exercises

Solutions to Selected Exercises

4 Let A be any set. Then for any x , $x \in \emptyset$ is a false statement, so $x \in \emptyset \Rightarrow x \in A$ is a true one. Hence $\emptyset \subseteq A$.

6 2. (i) $x \in \mathbf{C}CA \Leftrightarrow \neg\neg x \in A \Leftrightarrow x \in A$.

(ii) $x \in A \Rightarrow x \in A$.

(iii) $x \in U \Leftrightarrow x \in A \vee x \in \mathbf{C}A$.

(iv) $x \in A \cap \mathbf{C}A \Leftrightarrow x \in A \wedge x \notin A \Leftrightarrow x \in \emptyset$.

(vi) $x \in (A \cup (B \cap C)) \Leftrightarrow x \in A \vee (x \in B \wedge x \in C) \Leftrightarrow (x \in A \vee x \in B) \wedge (x \in A \vee x \in C) \Leftrightarrow x \in A \cup B \wedge x \in A \cup C \Leftrightarrow x \in (A \cup B) \cap (A \cup C)$.

(vii) $x \in A \cap (B \cap C) \Leftrightarrow x \in A \wedge (x \in B \wedge x \in C) \Leftrightarrow (x \in A \wedge x \in B) \wedge x \in C \Leftrightarrow x \in (A \cap B) \cap C$.

(ix) $x \in \mathbf{C}(A \cap B) \Leftrightarrow \neg(x \in A \cap B) \Leftrightarrow \neg(x \in A \wedge x \in B) \Leftrightarrow x \notin A \vee x \notin B \Leftrightarrow x \in \mathbf{C}A \vee x \in \mathbf{C}B \Leftrightarrow x \in \mathbf{C}A \cup \mathbf{C}B$.

3. (a) \Leftrightarrow (b). $A \subseteq B \Leftrightarrow \forall x(x \in A \Rightarrow x \in B) \Leftrightarrow \forall x(x \notin B \Rightarrow x \notin A) \Leftrightarrow \mathbf{C}B \subseteq \mathbf{C}A$.

(a) \Leftrightarrow (c) $A \subseteq B \Leftrightarrow \forall x(x \in A \Rightarrow x \in B) \Leftrightarrow \forall x((x \in A \vee x \in B) \Leftrightarrow x \in B) \Leftrightarrow A \cup B = B$.

(a) \Leftrightarrow (e) $A \cap \mathbf{C}B = \emptyset \Leftrightarrow \forall x\neg(x \in A \wedge x \in \mathbf{C}B) \Leftrightarrow \forall x(x \in A \Rightarrow x \notin \mathbf{C}B) \Leftrightarrow \forall x(x \in A \Rightarrow x \in B) \Leftrightarrow A \subseteq B$.

4.(i) $x \in A - (A \cap B) \Leftrightarrow x \in A \wedge x \notin A \cap B \Leftrightarrow x \in A \wedge (x \notin A \vee x \notin B) \Leftrightarrow (x \in A \wedge x \notin A) \vee (x \in A \wedge x \notin B) \Leftrightarrow x \in A \vee x \notin B \Leftrightarrow x \in A - B$.

(ii) Note that $B \subseteq (A - B) \cup B$, so if not $B \subseteq A$, then $(A - B) \cup B \neq A$.

7 (i) $(x, y) \in A \times (B \cup C) \Leftrightarrow x \in A \wedge y \in B \cup C \Leftrightarrow x \in A \wedge (y \in B \vee y \in C) \Leftrightarrow (x \in A \wedge y \in B) \vee (x \in A \wedge y \in C) \Leftrightarrow (x, y) \in A \times B \vee (x, y) \in A \times C \Leftrightarrow (x, y) \in (A \times B) \cup (A \times C)$.

(ii) Suppose $A \subseteq B$; then $(x, y) \in A \times C \Rightarrow x \in A \wedge y \in C \Rightarrow x \in B \wedge y \in C \Rightarrow (x, y) \in B \times C$. Conversely suppose $C \neq \emptyset$ and fix an element $c \in C$. If $A \times C \subseteq B \times C$, then $x \in A \Rightarrow (x, c) \in A \times C \Rightarrow (x, c) \in B \times C \Rightarrow x \in B$.

8 2. (ii) $(x, y) \in (S \circ R)^{-1} \Leftrightarrow (y, x) \in (S \circ R) \Leftrightarrow \exists z(yRz \wedge zSx) \Leftrightarrow \exists z(zR^{-1}y \wedge xS^{-1}z) \Leftrightarrow (x, y) \in R^{-1} \circ S^{-1}$.

9 Let $U = a_R$, $V = b_R$ be two equivalence classes. If $U \cap V \neq \emptyset$, then there is c such that $c \in a_R \cap b_R$, i.e., $cRa \wedge cRb$, whence by symmetry $aRc \wedge cRb$, so that aRb by transitivity. So if $x \in U$, then xRa , and, since aRb , xRb follows by transitivity. Therefore $U \subseteq V$; similarly $V \subseteq U$, so that $U = V$.

10 **1.** If \leq is a partial ordering, then it is transitive, i.e., $x \leq y \wedge y \leq z \Rightarrow x \leq z$. This is equivalent to $y \leq^{-1} x \wedge z \leq^{-1} y \Rightarrow z \leq^{-1} x$, in other words to the transitivity of \leq^{-1} . Similarly for the remaining conditions.

2. If R is a preordering, then S is easily verified to be reflexive and transitive. It is also obviously symmetric, and hence an equivalence relation.

11-12 **1.** To show that $g \circ f$ is a function, we need to show that, for any $x \in A$, there is at most one $u \in C$ such that $(x, u) \in g \circ f$. If $(x, u) \in g \circ f$ and $(x, u') \in g \circ f$, then for some $b, b' \in B$ we have $(x, b) \in f \wedge (b, u) \in g$ and $(x, b') \in f \wedge (b', u') \in g$. Then $b = b'$ because f is a function and hence $u = u'$ because g is a function.

2. (ii) Suppose f and g are one-to-one. Then $(g \circ f)(x) = (g \circ f)(y) \Rightarrow g(f(x)) = g(f(y)) \Rightarrow f(x) = f(y) \Rightarrow x = y$. So $g \circ f$ is one-to-one.

3. (ii) Suppose $X \subseteq Y$. Then $y \in f[X] \Rightarrow \exists x \in X \ y = f(x) \Rightarrow \exists x \in Y \ y = f(x) \Rightarrow y \in f[Y]$. So $f[X] \subseteq f[Y]$. **(iii)** $z \in f[X \cup Y] \Leftrightarrow \exists x \in X \cup Y \ z = f(x) \Leftrightarrow \exists x \in X \ z = f(x) \vee \exists x \in Y \ z = f(x) \Leftrightarrow z \in f[X] \vee z \in f[Y] \Leftrightarrow z \in f[X] \cup f[Y]$. Hence $f[X \cup Y] = f[X] \cup f[Y]$. In general $f[X \cap Y] \subseteq f[X] \cap f[Y]$. But they are not always equal, for consider the function $f: \{0, 1\} \rightarrow \{0\}$ defined by $f(0) = f(1) = 0$, and let $X = \{0\}$, $Y = \{1\}$. Then $X \cap Y = \emptyset$, so $f[X \cap Y] = \emptyset$. But $f[X] = f[Y] = \{0\}$, so $f[X \cap Y] \neq f[X] \cap f[Y]$.

4. (ii) $x \in g^{-1}[Y \cup Z] \Leftrightarrow g(x) \in Y \cup Z \Leftrightarrow g(x) \in Y \vee g(x) \in Z \Leftrightarrow x \in g^{-1}[Y] \vee x \in g^{-1}[Z] \Leftrightarrow x \in g^{-1}[Y \cup Z]$. **(iii)** $x \in X \Rightarrow g(x) \in g[X] \Rightarrow x \in g^{-1}[g[X]]$. Hence $X \subseteq g^{-1}[g[X]]$. Now suppose that g is one-to-one. We already know that $X \subseteq g^{-1}[g[X]]$. If $y \in g^{-1}[g[X]]$, then $g(y) \in g[X]$, so $g(y) = g(x)$ for some $x \in X$, whence $y = x \in X$ since g is one-to-one. Therefore $g^{-1}[g[X]] \subseteq X$, so $X = g^{-1}[g[X]]$.

21 **1. (iii)** Suppose that $\forall xPx \rightarrow \forall xQx$ is true under \mathbf{I} . This means that either $\forall xPx$ is false or $\forall xQx$ is true under \mathbf{I} . In the first case, there is some a such that $a \in P^{\mathbf{I}}$ is false. Then $\forall y(Pa \rightarrow Qy)$ is true under \mathbf{I}_a^n , so that $\exists x \forall y(Px \rightarrow Qy)$ is true under \mathbf{I} . In the second case, fix a in the domain of \mathbf{I} . Then since $\forall xQx$ is true under \mathbf{I} , Qm is true under \mathbf{I}_b^m for any b in the domain of \mathbf{I} . It follows that $Pa \rightarrow Qm$ is true under \mathbf{I}_{ba}^{mn} for any b , so that $\forall y(Pa \rightarrow Qy)$ is true under \mathbf{I}_a^n , and again $\exists x \forall y(Px \rightarrow Qy)$ is true under \mathbf{I} .

4. (i) is valid. For either $\forall yPy$ is true under \mathbf{I} or it is false under \mathbf{I} . In the first case $\exists x(Px \rightarrow \forall yPy)$ is clearly true under \mathbf{I} . In the second case, we can choose $a \notin P^{\mathbf{I}}$, so that $a \in P^{\mathbf{I}} \Rightarrow (\forall yPy \text{ is true under } \mathbf{I})$ is true since $a \in P^{\mathbf{I}}$ is false. Hence $\exists x(Px \rightarrow \forall yPy)$ is true in the second case as well.

(iii) is invalid. Counterinterpretation \mathbf{I} : domain: set of natural numbers; $P^{\mathbf{I}}$: set of even numbers; $Q^{\mathbf{I}}$: set of odd numbers.

5. (i) Satisfiable. Satisfying interpretation \mathbf{I} : domain: set of natural numbers; $P^{\mathbf{I}}$: set of natural numbers; $R^{\mathbf{I}}$: "less than" relation.

6. (i) $\forall x\forall y(Px \wedge Py \rightarrow x = y)$. (ii) $\forall x\forall y\forall z(Px \wedge Py \wedge Pz \rightarrow x = y \vee x = z \vee y = z)$. (iii) $\exists x\exists y(Px \wedge Py \wedge x \neq y)$. (v) $\exists x\exists y(x \neq y \wedge \forall z(Pz \leftrightarrow (x = z \vee y = z)))$.

23 1.(i) $a = gfb \vee a = ggb$. (iii) $Pa \wedge a \neq gb \wedge fa = fgb \wedge ga = ggb$. (v) $fa = fb \wedge ga = gb \wedge a \neq b$.

2. (ii) a and b are half siblings. (iv) b is a 's uncle.

26 (iv)

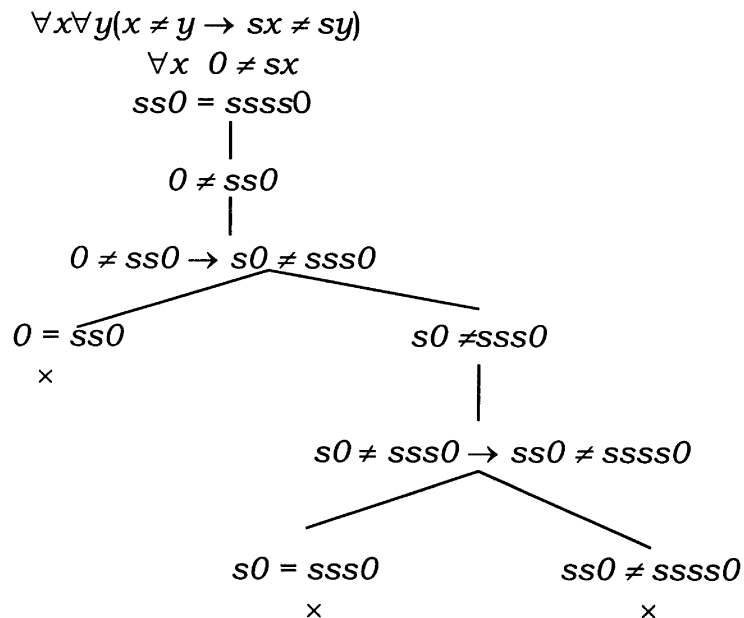

(vi)

$$\begin{array}{c}
 \forall x \ x + 0 = x \\
 \forall x\forall y \ x \times sy = (x \times y) + x \\
 \forall x \ x \times 0 = 0 \\
 0 \times ss0 \neq 0 \\
 | \\
 0 \times ss0 = (0 \times s0) + 0 \\
 |
 \end{array}$$

$$\begin{array}{l}
 (0 \times s0) + 0 = 0 \times s0 \\
 0 \times ss0 \neq 0 \times s0 \\
 | \\
 0 \times s0 = (0 \times 0) + 0 \\
 | \\
 (0 \times 0) + 0 = 0 \times 0 \\
 | \\
 0 \times s0 = 0 \times 0 \\
 | \\
 0 \times 0 = 0 \\
 | \\
 0 \times s0 = 0 \\
 | \\
 0 \times ss0 = 0 \\
 \times
 \end{array}$$

28 2. (b)

$$\begin{array}{l}
 \forall x \ x + 0 = x \\
 \forall x \ x + sy = s(x + y) \\
 | \\
 \neg \forall x \ 0 + x = x \\
 | \\
 0 + a \neq a \\
 | \\
 0 + 0 = 0 \\
 | \\
 0 + b = b \\
 0 + sb \neq sb \\
 | \\
 0 + sb = s(0 + b) \\
 | \\
 0 + sb = sb \\
 \times
 \end{array}$$

32 (ii)

$$\begin{array}{l}
 \forall P(Pa \rightarrow Pb) \\
 \neg \forall P(Pb \rightarrow Pa) \\
 | \\
 \exists P \neg (Pb \rightarrow Pa) \\
 |
 \end{array}$$

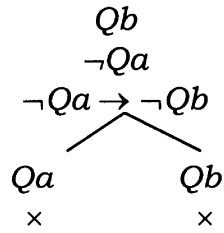

42 1.

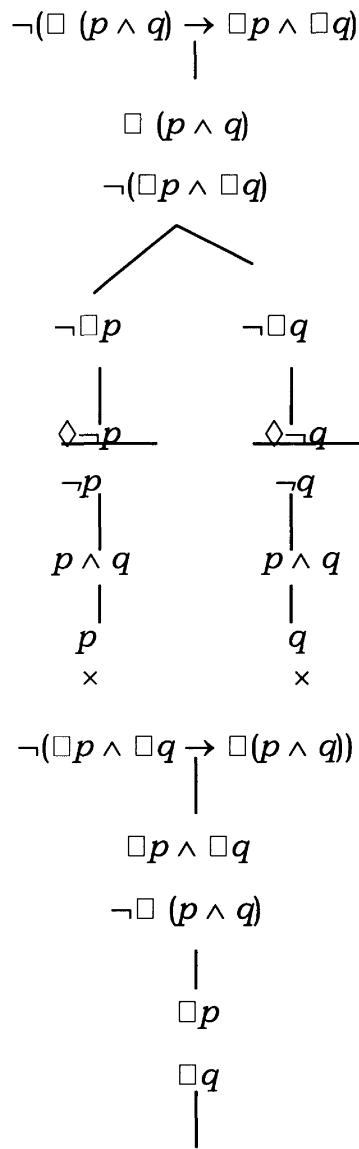

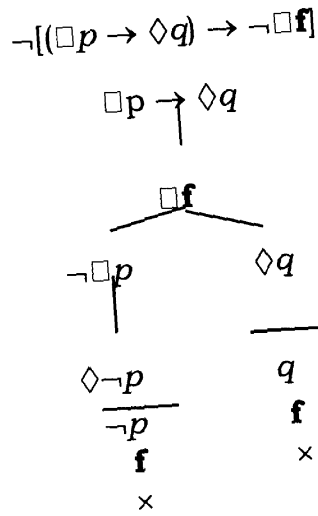
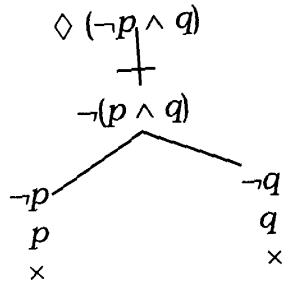

47 (iii)

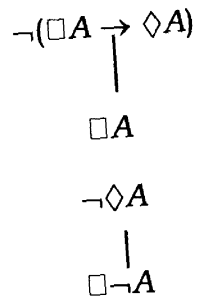

t or f
.

(v)

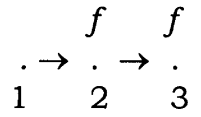
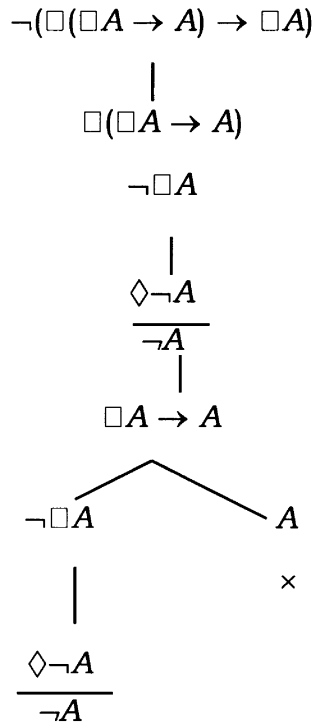

48

1.

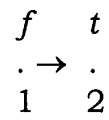
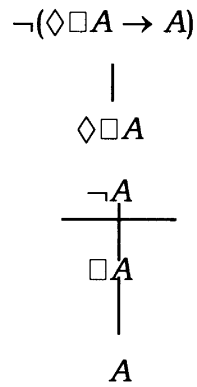

50 1.

$$\neg(\Box\Diamond\Box\Diamond p \rightarrow \Box\Diamond p)$$

$$\Box\Diamond\Box\Diamond p$$

$$\neg\Box\Diamond p$$

|

$$\Diamond\neg\Diamond p$$

$$\hline\neg\Diamond p$$

$$\Diamond\Box\Diamond p$$

$$\Box\neg p$$

$$\hline\Box\Diamond p$$

$$\Box\neg p$$

$$\Diamond p$$

$$\hline p$$

$$\neg p$$

x

$$\neg(\Box\Diamond p \rightarrow \Box\Diamond\Box\Diamond p)$$

|

$$\Box\Diamond p$$

$$\neg\Box\Diamond\Box\Diamond p$$

$$\Diamond\neg\Box\Diamond p$$

$$\begin{array}{c}
 \overline{\neg \diamond \Box \diamond p} \\
 | \\
 \diamond p \\
 | \\
 \overline{\Box \neg \Box \diamond p} \\
 p \\
 | \\
 \neg \Box \diamond p \\
 | \\
 \Box \diamond p \\
 \times
 \end{array}$$

2.

$$\begin{array}{c}
 \neg(\Box \diamond A \rightarrow A) \\
 | \\
 \Box \diamond A \\
 \neg A \\
 | \\
 \diamond A \\
 \hline
 A
 \end{array}$$

$$\begin{array}{cc}
 f & t \\
 \vdots & \rightarrow & \vdots \\
 1 & & 2
 \end{array}$$

51. 1 (v)

$$\begin{array}{c}
 \neg(\Box \diamond \Box \diamond p \rightarrow \Box \diamond p) \\
 | \\
 \Box \diamond \Box \diamond p \\
 | \\
 \neg \Box \diamond p \\
 | \\
 \diamond \neg \diamond p \\
 \hline
 \neg \diamond p \\
 \diamond \Box \diamond p \\
 \hline
 \Box \neg p \\
 \Box \diamond p \\
 \times
 \end{array}$$

$$\begin{array}{c}
 \neg(\Box\Diamond p \rightarrow \Box\Diamond\Box\Diamond p) \\
 \quad | \\
 \quad \Box\Diamond p \\
 \quad \quad | \\
 \quad \quad \neg\Box\Diamond\Box\Diamond p \\
 \quad \quad \quad | \\
 \quad \quad \quad \Diamond\neg\Box\Diamond p \\
 \quad \quad \quad \quad | \\
 \quad \quad \quad \quad \neg\Diamond\Box\Diamond p \\
 \quad \quad \quad \quad \quad | \\
 \quad \quad \quad \quad \quad \Box\neg\Box\Diamond p \\
 \quad \quad \quad \quad \quad \quad | \\
 \quad \quad \quad \quad \quad \quad \times
 \end{array}$$

591. (x)

$$\begin{array}{c}
 ?\neg\neg\neg p \rightarrow \neg p \\
 \hline
 \quad | \\
 \quad \neg\neg\neg p \\
 \quad \quad | \\
 \quad \quad ?\neg p \\
 \quad \quad \quad | \\
 \quad \quad \quad \neg p \\
 \quad \quad \quad \quad | \\
 \quad \quad \quad \quad \neg\neg\neg p \\
 \quad \quad \quad \quad \quad | \\
 \quad \quad \quad \quad \quad ?\neg\neg\neg p \\
 \quad \quad \quad \quad \quad \quad | \\
 \quad \quad \quad \quad \quad \quad \neg p \\
 \quad \quad \quad \quad \quad \quad \quad | \\
 \quad \quad \quad \quad \quad \quad \quad p \\
 \quad \quad \quad \quad \quad \quad \quad \quad | \\
 \quad \quad \quad \quad \quad \quad \quad \quad \times
 \end{array}$$

$$\begin{array}{c}
 ?\neg p \rightarrow \neg\neg\neg p \\
 \hline
 \quad | \\
 \quad \neg p \\
 \quad \quad | \\
 \quad \quad ?\neg\neg\neg p \\
 \quad \quad \quad | \\
 \quad \quad \quad \neg p
 \end{array}$$

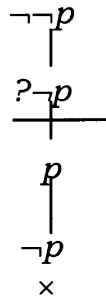

(xv)

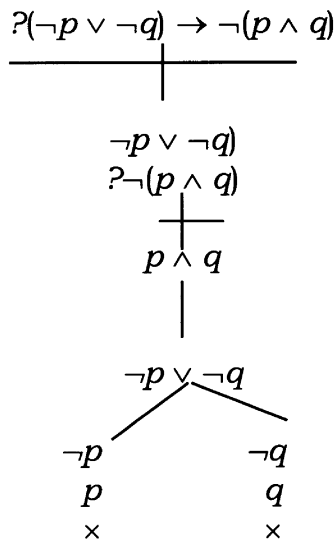

68 (i)

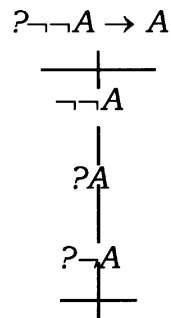

f	f	t
$\cdot \rightarrow$	$\cdot \rightarrow$	\cdot
1	2	3

(ii)

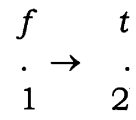
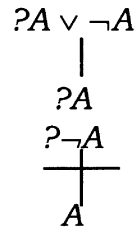

(iii)

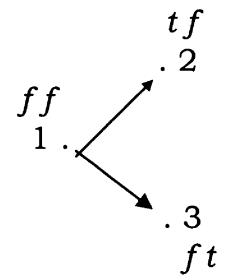
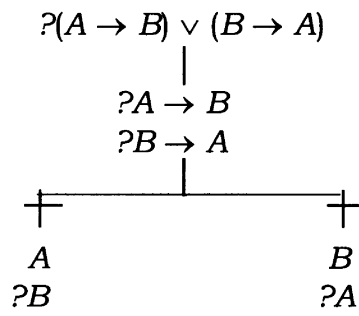

Non-Returnable

Non-Returnable

PHILOSOPHY 3201B
SECOND COURSE IN LOGIC

NOTICE REGARDING COPYRIGHT

This custom course book contains intellectual property that is protected by copyright. It is illegal to copy this book without the written consent of the Dept. or Faculty. This book has been copied with permission from the Dept. of Faculty. Resale or further copying of this book is strictly prohibited.

M9718



THE
BOOK
STORE
AT WESTERN



*This copy was digitally stored and printed by
UWO - Graphic Services.*

Graphic Services and the Book Store are not
responsible for content under any
circumstances.

This book has been printed on SFI paper.